

Memory FeRAM

64 K (8 K × 8) Bit I²C

MB85RC64V

■ DESCRIPTION

The MB85RC64V is an FeRAM (Ferroelectric Random Access Memory) chip in a configuration of 8,192 words × 8 bits, using the ferroelectric process and silicon gate CMOS process technologies for forming the nonvolatile memory cells.

Unlike SRAM, the MB85RC64V is able to retain data without using a data backup battery.

The read/write endurance of the nonvolatile memory cells used for the MB85RC64V has improved to be at least 10¹² cycles, significantly outperforming other nonvolatile memory products in the number.

The MB85RC64V does not need a polling sequence after writing to the memory such as the case of Flash memory or E²PROM.

■ FEATURES

- Bit configuration : 8,192 words × 8 bits
- Two-wire serial interface : Fully controllable by two ports: serial clock (SCL) and serial data (SDA).
- Operating frequency : 1 MHz (Max)
- Read/write endurance : 10¹² times / byte
- Data retention : 10 years (+ 85 °C), 95 years (+ 55 °C), over 200 years (+ 35 °C)
- Operating power supply voltage: 3.0 V to 5.5 V
- Low-power consumption : Operating power supply current 90 μA (Typ @1 MHz)
Standby current 5 μA (Typ)
- Operation ambient temperature range : - 40 °C to + 85 °C
- Package : 8-pin plastic SOP (150mil)
RoHS compliant

Fujitsu Semiconductor Memory Solutions Limited has changed its name to RAMXEED Limited. RAMXEED Limited will continue to offer and support existing products while maintaining Fujitsu's part number unchanged.

MB85RC64V

■ PIN ASSIGNMENT

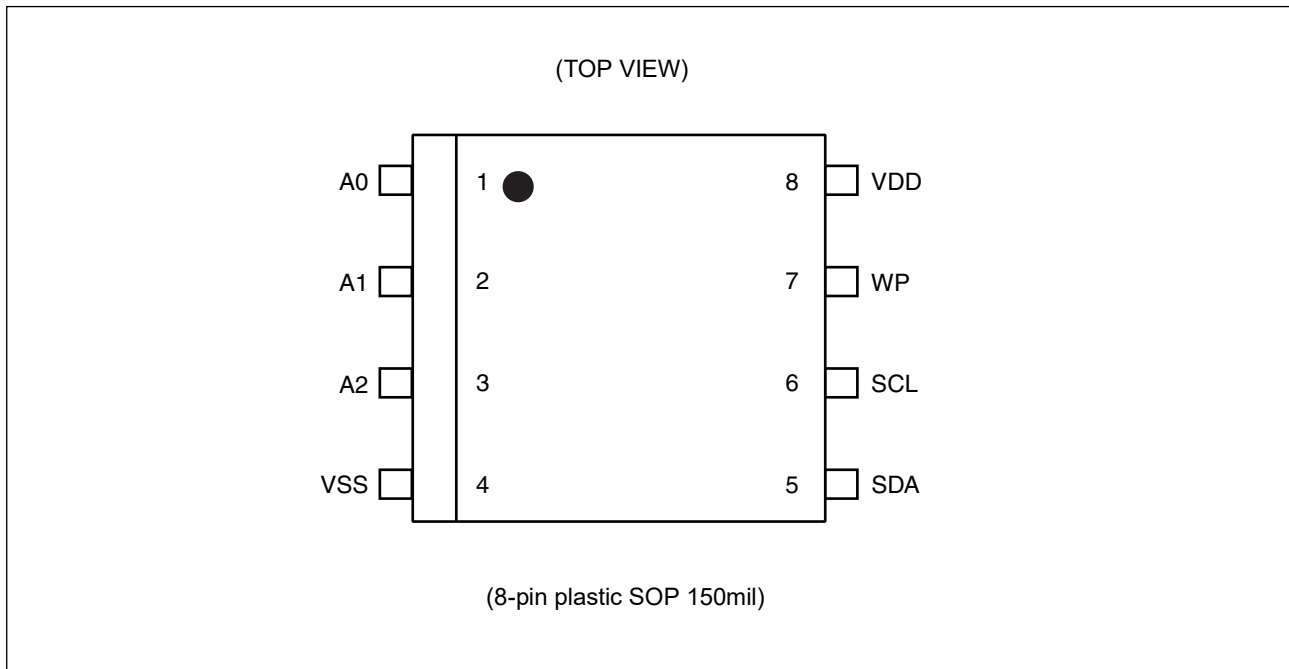

■ PIN FUNCTIONAL DESCRIPTIONS

Pin Number	Pin Name	Functional Description
1 to 3	A0 to A2	Device Address pins The MB85RC64V can be connected to the same data bus up to 8 devices. Device addresses are used in order to identify each of these devices. Connect these pins to VDD pin or VSS pin externally. Only if the combination of VDD and VSS pins matches a Device Address Code inputted from the SDA pin, the device operates. In the open pin state, A0, A1 and A2 pins are internally pulled-down and recognized as the "L" level.
4	VSS	Ground pin
5	SDA	Serial Data I/O pin This is an I/O pin which performs bidirectional communication for both memory address and writing/reading data. It is possible to connect multiple devices. It is an open drain output, so a pull-up resistor is required to be connected to the external circuit.
6	SCL	Serial Clock pin This is a clock input pin for input/output serial data. Data is sampled on the rising edge of the clock and output on the falling edge.
7	WP	Write Protect pin When the Write Protect pin is the "H" level, the writing operation is disabled. When the Write Protect pin is the "L" level, the entire memory region can be overwritten. The reading operation is always enabled regardless of the Write Protect pin input level. The Write Protect pin is internally pulled down to VSS pin, and that is recognized as the "L" level (write enabled) when the pin is the open state.
8	VDD	Supply Voltage pin

■ BLOCK DIAGRAM

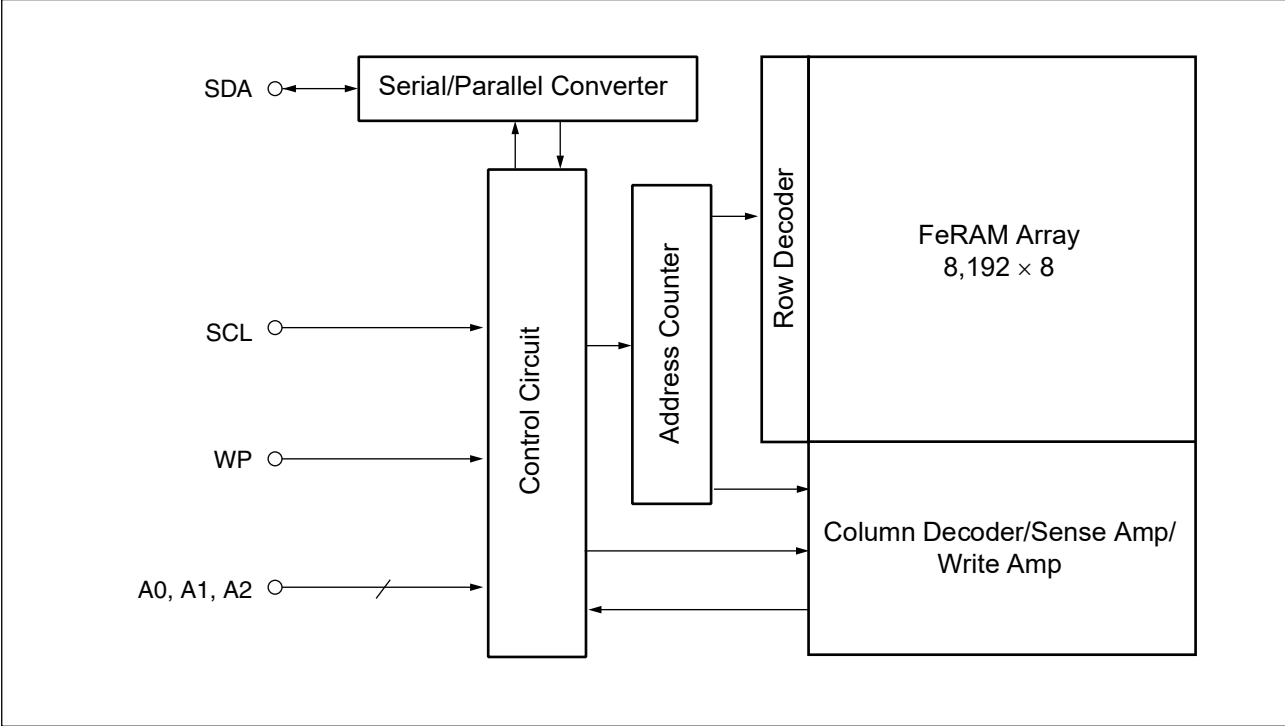

■ I²C (Inter-Integrated Circuit)

The MB85RC64V has the two-wire serial interface; the I²C bus, and operates as a slave device. The I²C bus defines communication roles of “master” and “slave” devices, with the master side holding the authority to initiate control. Furthermore, an I²C bus connection is possible where a single master device is connected to multiple slave devices in a party-line configuration. In this case, it is necessary to assign a unique device address to the slave device, the master side starts communication after specifying the slave to communicate by addresses.

● I²C Interface System Configuration Example

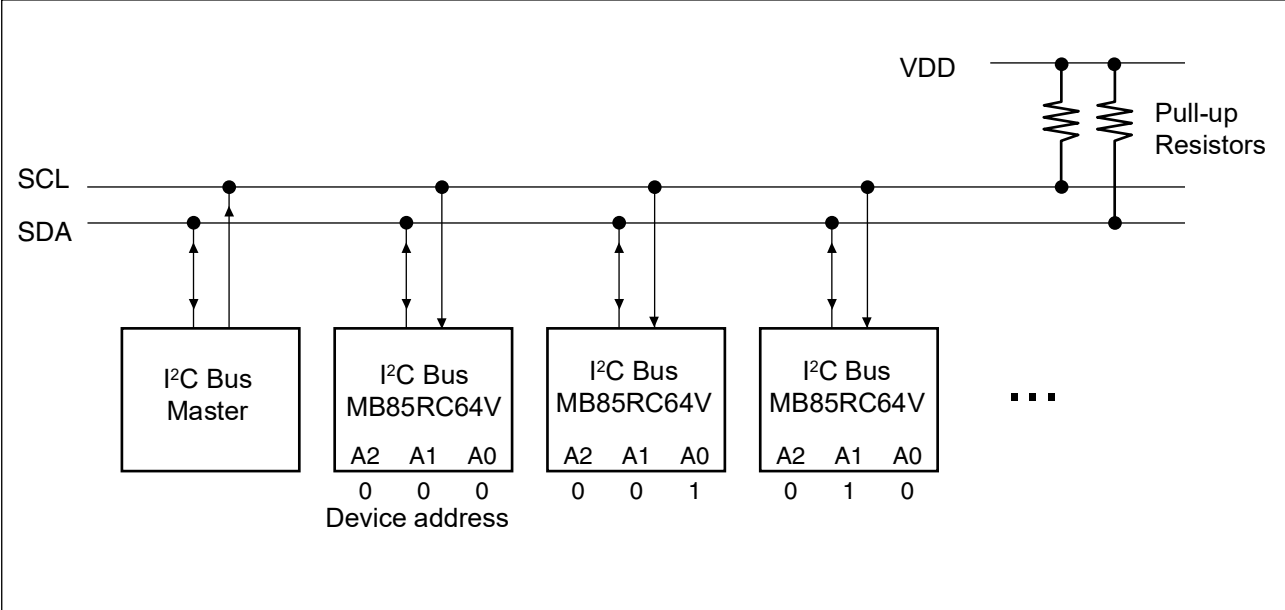

■ I²C COMMUNICATION PROTOCOL

The I²C bus is a two wire serial interface that uses a bidirectional data bus (SDA) and serial clock (SCL). A data transfer can only be initiated by the master, which will also provide the serial clock for synchronization. The SDA signal should change while the SCL is the “L” level. However, as an exception, when starting and stopping communication sequence, the SDA is allowed to change while the SCL is the “H” level.

- Start Condition

To start read or write operations by the I²C bus, change the SDA input from the “H” level to the “L” level while the SCL input is in the “H” level.

- Stop Condition

To stop the I²C bus communication, change the SDA input from the “L” level to the “H” level while the SCL input is in the “H” level. In the reading operation, inputting the stop condition finishes reading and enters the standby state. In the writing operation, inputting the stop condition finishes inputting the rewrite data and enters the standby state.

- Start Condition, Stop Condition

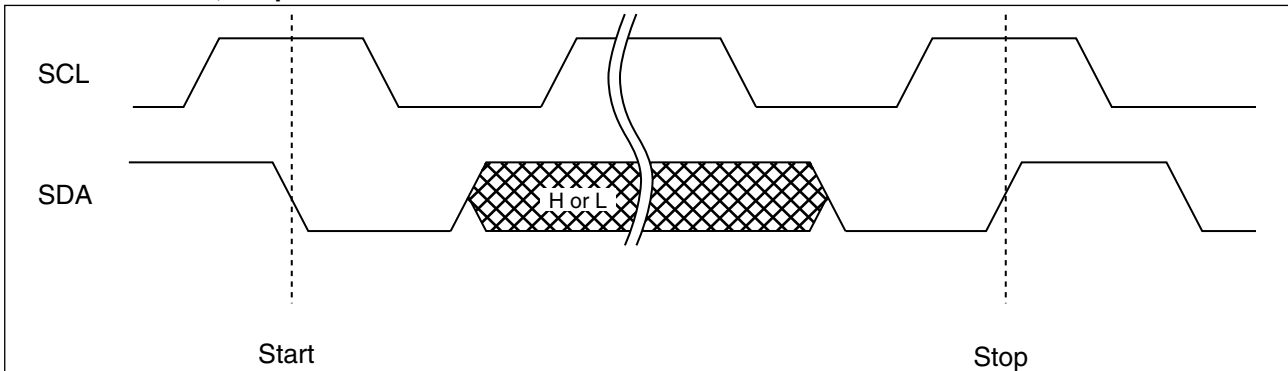

Note : At the write operation, the FeRAM device does not need the programming wait time (t_{wc}) after issuing the Stop Condition.

■ ACKNOWLEDGE (ACK)

In the I²C bus, serial data including address or memory information is sent in units of 8 bits. The acknowledge signal indicates that every 8 bits of the data is successfully sent and received. The receiver side usually outputs the “L” level every time on the 9th SCL clock after each 8 bits are successfully transmitted and received. On the transmitter side, the bus is temporarily released to Hi-Z every time on this 9th clock to allow the acknowledge signal to be received and checked. During this Hi-Z released period, the receiver side pulls the SDA line down to indicate the “L” level that the previous 8 bits communication is successfully received.

In case the slave side receives Stop condition before sending or receiving the ACK “L” level, the slave side stops the operation and enters to the standby state. On the other hand, the slave side releases the bus state after sending or receiving the NACK “H” level. The master side generates Stop condition or Start condition in this released bus state.

- Acknowledge timing overview diagram

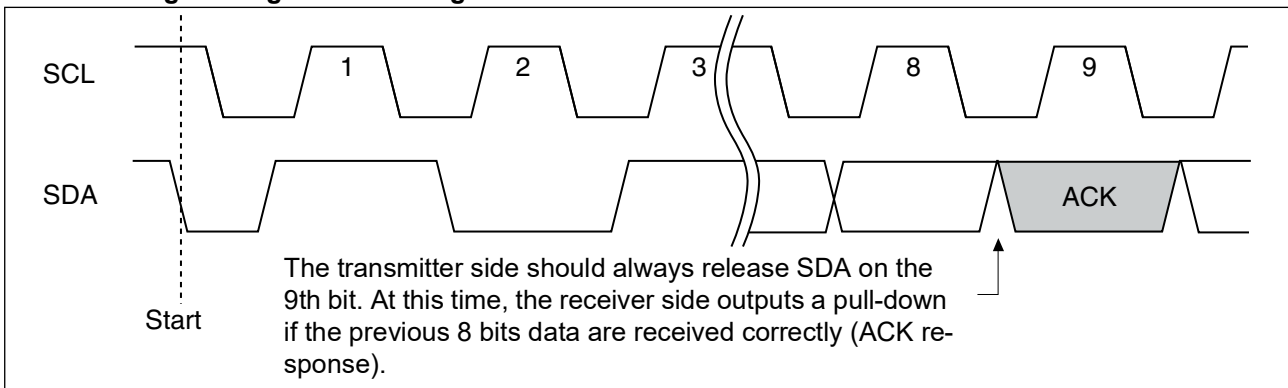

■ DEVICE ADDRESS WORD (Slave address)

Following the start condition, the master sends the 8 bits device address word to start I²C communication. The device address word (8 bits) consists of a device Type code (4 bits), device address code (3 bits), and a read/write code (1 bit).

- Device Type Code (4 bits)

The upper 4 bits of the device address word are a device type code that identifies the device type, and are fixed at "1010" for the MB85RC64V.

- Device Address Code (3 bits)

Following the device type code, the 3 bits of the device address code are input in order of A2, A1 and A0. The device address code identifies one device from up to eight devices connected to the bus. Each MB85RC64V is given a unique 3 bits code on the device address pin (external hardware pin A2, A1 and A0). The slave only responds if the received device address code is equal to this unique 3 bits code.

- Read/Write Code (1 bit)

The 8th bit of the device address word is the R/W (read/write) code. When the R/W code is "0", a write operation is enabled, and the R/W code is "1", a read operation is enabled for the MB85RC64V.

It turns to a stand-by state if the device code is not "1010" or device address code does not equal to pins A2, A1 and A0.

• Device Address Word

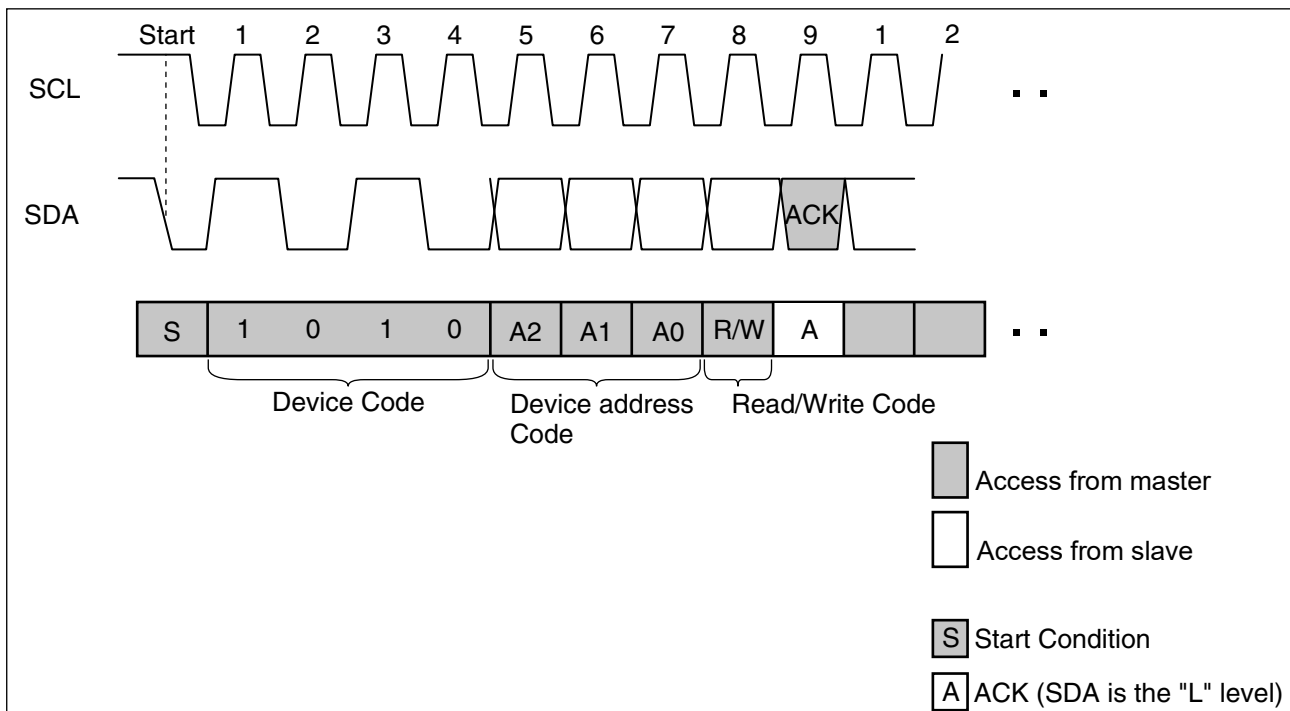

■ DATA STRUCTURE

In the I²C bus, the acknowledge "L" level is output on the 9th bit by a slave, after the 8 bits of the device address word following the start condition are input by a master. After confirming the acknowledge response by the master, the master outputs 8 bits × 2 memory address to the slave. When the each memory address input ends, the slave again outputs the acknowledge "L" level. After this operation, the I/O data follows in units of 8 bits, with the acknowledge "L" level output after every 8 bits.

It is determined by the R/W code whether the data line is driven by the master or the slave. However, the clock line shall be driven by the master. For a write operation, the slave will accept 8 bits from the master, then send an acknowledge. If the master detects the acknowledge, the master will transfer the next 8 bits. For a read operation, the slave will place 8 bits on the data line, then wait for an acknowledge from the master.

■ FeRAM ACKNOWLEDGE -- POLLING NOT REQUIRED

The MB85RC64V performs the high speed write operations, so any waiting time for an ACK polling* does not occur.

- *: In E²PROM, the Acknowledge Polling is performed as a progress check whether rewriting is executed or not. It is normal to judge by the 9th bit of Acknowledge whether rewriting is performed or not after inputting the start condition and then the device address word (8 bits) during rewriting.

■ WRITE PROTECT (WP)

The entire memory array can be write protected using the Write Protect pin. When the Write Protect pin is set to the "H" level, the entire memory array will be write protected. When the Write Protect pin is the "L" level, the entire memory array will be rewritten. Reading is allowed regardless of the WP pin's "H" level or "L" level.

Note : The Write Protect pin is pulled down internally to the VSS pin, therefore if the Write Protect pin is open, the pin status is detected as the "L" level (write enabled).

■ COMMAND

• Byte Write

If the device address word (R/W "0" input) is sent following the start condition, the slave responds with an ACK. After this ACK, write addresses and data are sent in the same way, and the write ends by generating a stop condition at the end.

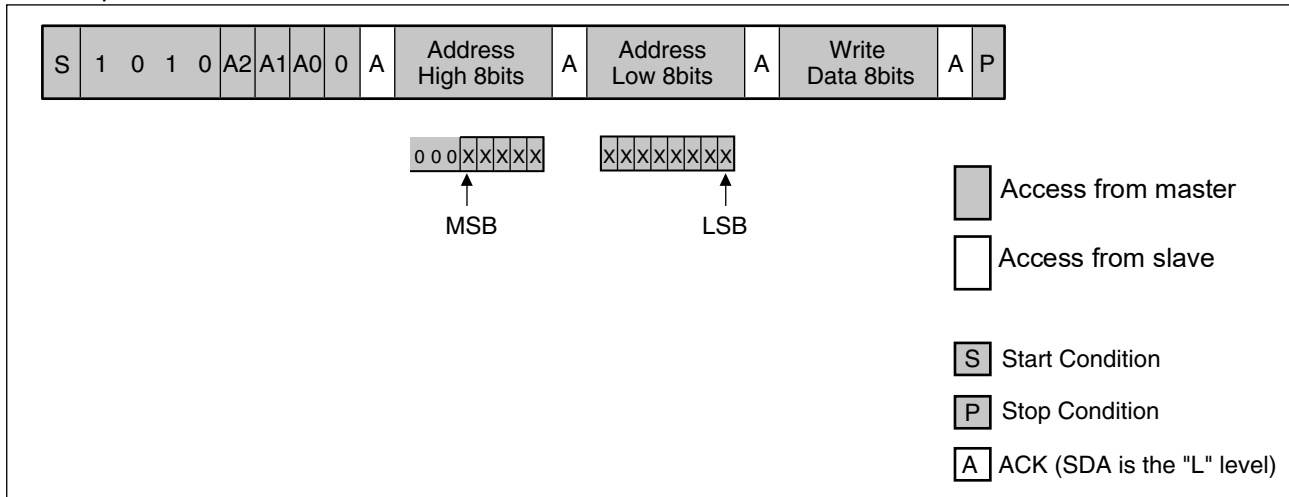

Note : In the MB85RC64V, input "000" to the upper 3 bits of the MSB because the address is expressed with 13 bits.

• Page Write

If additional 8 bits are continuously sent after the same command (except stop condition) as Byte Write, a page write is performed. The memory address rolls over to first memory address (0000_H) at the end of the address. Therefore, if more than 8 Kbytes are sent, the data is overwritten in order starting from the start of the memory address that was written first. Because FeRAM performs the high-speed write operations, the data will be written to FeRAM right after the ACK response finished.

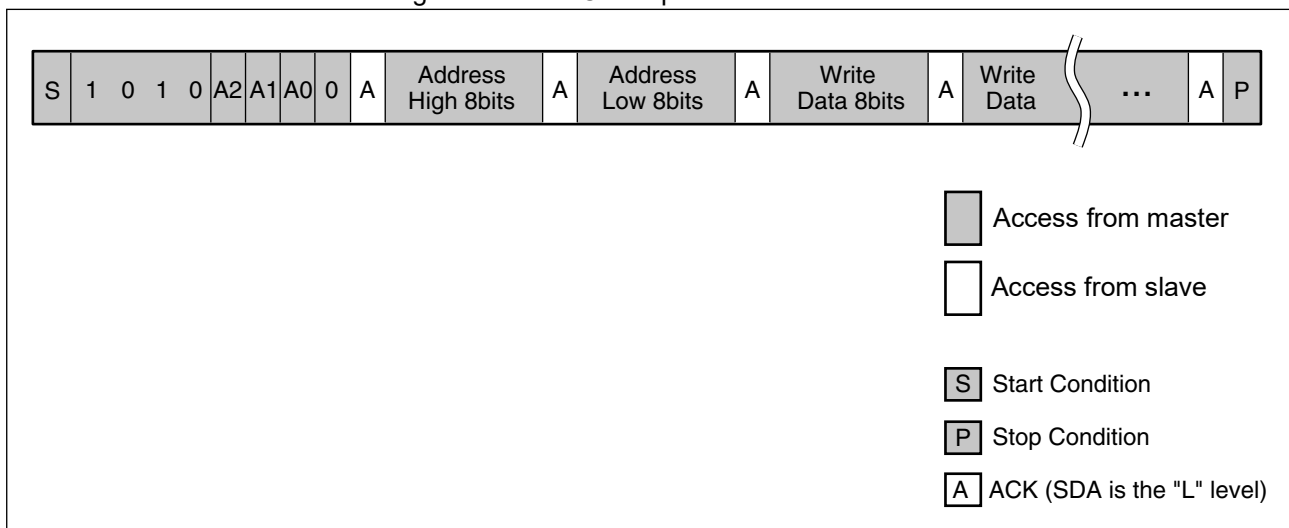

Note : It is not necessary to take a period for internal write operation cycles from the buffer to the memory after the stop condition is generated.

MB85RC64V

- Current Address Read

When the previous write or read operation finishes successfully up to the stop condition and assumes the last accessed address is “n”, then the address at “n+1” is read by sending the following command unless turning the power off. If the memory address is last address, the address counter will roll over to 0000H. The current address in memory address buffer is undefined immediately after the power is turned on.

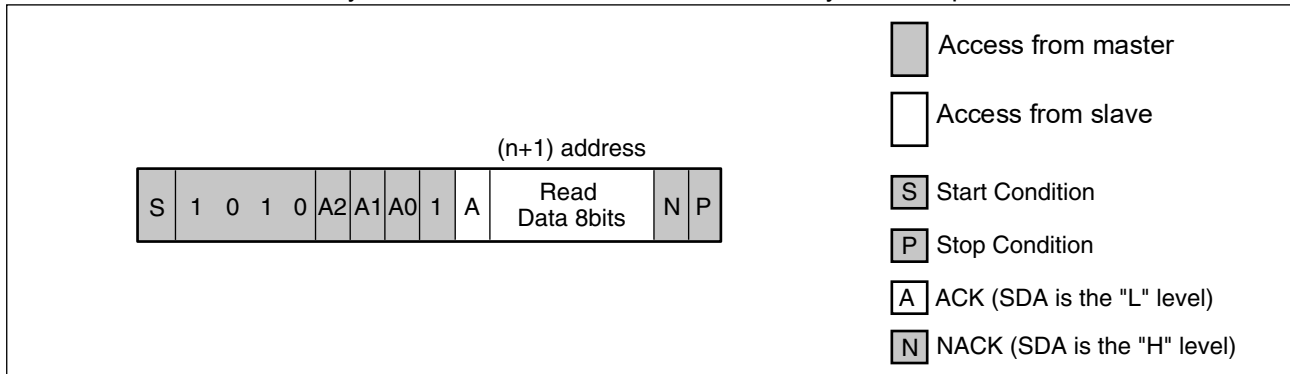

- Random Read

The one byte of data from the memory address saved in the memory address buffer can be read out synchronously to SCL by specifying the address in the same way as for a write, and then issuing another start condition and sending the Device Address Word (R/W “1” input).

The final NACK (SDA is the "H" level) is issued by the receiver that receives the data. In this case, this bit is issued by the master side.

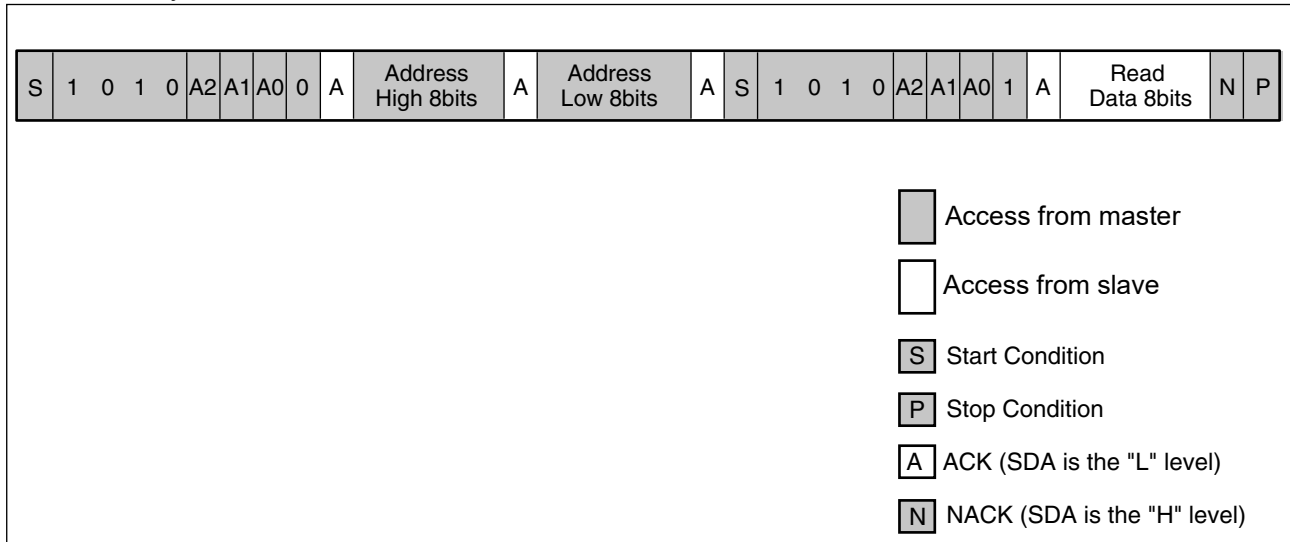

- Sequential Read

Data can be received continuously following the Device address word (R/W "1" input) after specifying the address in the same way as for Random Read. If the read reaches the end of address, the internal read address automatically rolls over to first memory address 0000_H and keeps reading.

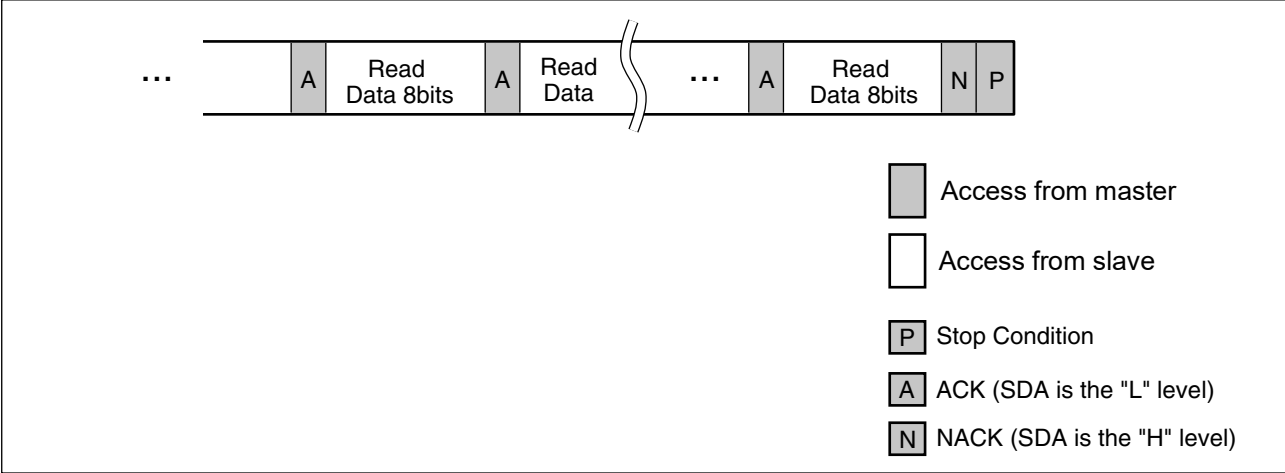

■ SOFTWARE RESET SEQUENCE OR COMMAND RETRY

In case the malfunction has occurred after power on, the master side stopped the I²C communication during processing, or unexpected malfunction has occurred, execute the following (1) software recovery sequence just before each command, or (2) retry command just after failure of each command.

(1) Software Reset Sequence

Since the slave side may be outputting "L" level, do not force to drive "H" level, when the master side drives the SDA port. This is for preventing a bus conflict. The additional hardware is not necessary for this software reset sequence.

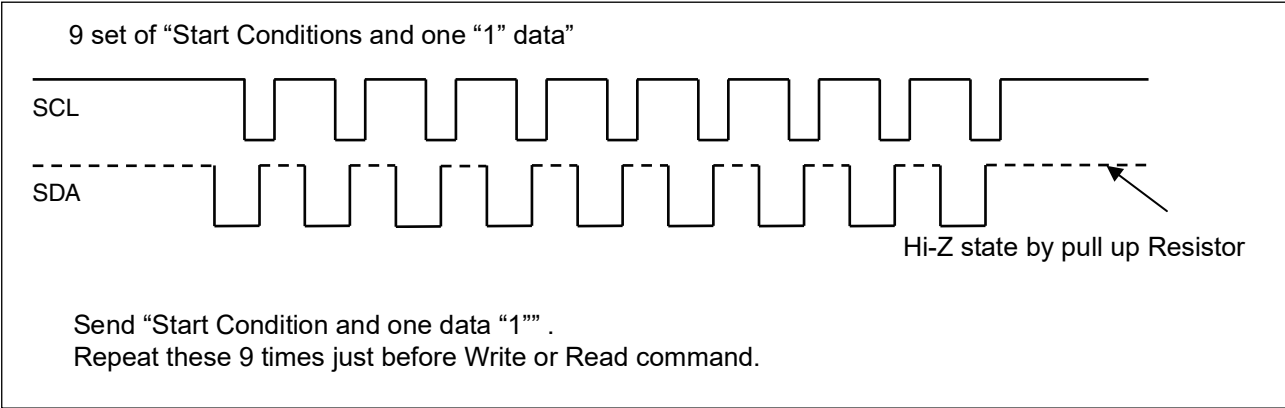

(2) Command Retry

Command retry is useful to recover from failure response during I²C communication.

MB85RC64V

■ ABSOLUTE MAXIMUM RATINGS

Parameter	Symbol	Rating		Unit
		Min	Max	
Power supply voltage*	V _{DD}	- 0.5	+ 6.0	V
Input voltage*	V _{IN}	- 0.5	V _{DD} + 0.5 (≤ 6.0)	V
Output voltage*	V _{OUT}	- 0.5	V _{DD} + 0.5 (≤ 6.0)	V
Operation ambient temperature	T _A	- 40	+ 85	°C
Storage temperature	T _{stg}	- 55	+ 125	°C

*: These parameters are based on the condition that VSS is 0 V.

WARNING: Semiconductor devices can be permanently damaged by application of stress (voltage, current, temperature, etc.) in excess of absolute maximum ratings. Do not exceed these ratings.

■ RECOMMENDED OPERATING CONDITIONS

Parameter	Symbol	Value			Unit
		Min	Typ	Max	
Power supply voltage ^{*1}	V _{DD}	3.0	—	5.5	V
Operation ambient temperature ^{*2}	T _A	- 40	—	+ 85	°C

*1: These parameters are based on the condition that VSS is 0 V.

*2: Ambient temperature when only this device is working. Please consider it to be the almost same as the package surface temperature.

WARNING: The recommended operating conditions are required in order to ensure the normal operation of the semiconductor device. All of the device's electrical characteristics are warranted when the device is operated within these ranges.

Always use semiconductor devices within their recommended operating condition ranges. Operation outside these ranges may adversely affect reliability and could result in device failure. No warranty is made with respect to uses, operating conditions, or combinations not represented on the data sheet. Users considering application outside the listed conditions are advised to contact their representatives beforehand.

■ ELECTRICAL CHARACTERISTICS

1. DC Characteristics

(within recommended operating conditions)

Parameter	Symbol	Condition	Value			Unit
			Min	Typ	Max	
Input leakage current*1	I _{LI}	V _{IN} = 0 V to V _{DD}	—	—	1	μA
Output leakage current*2	I _{LO}	V _{OUT} = 0 V to V _{DD}	—	—	1	μA
Operating power supply current	I _{DD}	SCL = 400 kHz	—	40	80	μA
		SCL = 1000 kHz	—	90	130	μA
Standby current	I _{SB}	SCL, SDA = V _{DD} WP = 0 V or V _{DD} or Open Under Stop Condition T _A = + 25 °C	—	5	10	μA
“H” level input voltage	V _{IH}	V _{DD} = 3.0 V to 5.5 V	V _{DD} × 0.8	—	5.5	V
“L” level input voltage	V _{IL}	V _{DD} = 3.0 V to 5.5 V	V _{SS}	—	V _{DD} × 0.2	V
“L” level output voltage	V _{OL}	I _{OL} = 3 mA	—	—	0.4	V
Input resistance for WP, A0, A1, and A2 pins	R _{IN}	V _{IN} = V _{IL} (Max)	50	—	—	kΩ
		V _{IN} = V _{IH} (Min)	1	—	—	MΩ

*1: Applicable pin: SCL,SDA

*2: Applicable pin: SDA

2. AC Characteristics

Parameter	Symbol	Value						Unit
		STANDARD MODE		FAST MODE		FAST MODE PLUS		
		Min	Max	Min	Max	Min	Max	
SCL clock frequency	F _{SCL}	0	100	0	400	0	1000	kHz
Clock high time	T _{HIGH}	4000	—	600	—	400	—	ns
Clock low time	T _{LOW}	4700	—	1300	—	600	—	ns
SCL/SDA rising time	T _r	—	1000	—	300	—	300	ns
SCL/SDA falling time	T _f	—	300	—	300	—	100	ns
Start condition hold	T _{HD:STA}	4000	—	600	—	250	—	ns
Start condition setup	T _{SU:STA}	4700	—	600	—	250	—	ns
SDA input hold	T _{HD:DAT}	20	—	20	—	20	—	ns
SDA input setup	T _{SU:DAT}	250	—	100	—	100	—	ns
SDA output hold	T _{DH:DAT}	0	—	0	—	0	—	ns
Stop condition setup	T _{SU:STO}	4000	—	600	—	250	—	ns
SDA output access after SCL falling	T _{AA}	—	3000	—	900	—	550	ns
Pre-charge time	T _{BUF}	4700	—	1300	—	500	—	ns
Noise suppression time (SCL and SDA)	T _{SP}	—	50	—	50	—	50	ns

AC characteristics were measured under the following measurement conditions.

Power supply voltage : STANDARD MODE and FAST MODE 3.0 V to 5.5 V
: FAST MODE PLUS 4.5 V to 5.5 V

Operation ambient temperature : - 40 °C to + 85 °C

Input voltage magnitude : $V_{DD} \times 0.2$ to $V_{DD} \times 0.8$

Input rising time : 5 ns

Input falling time : 5 ns

Input judge level : $V_{DD}/2$

Output judge level : $V_{DD}/2$

3. AC Timing Definitions

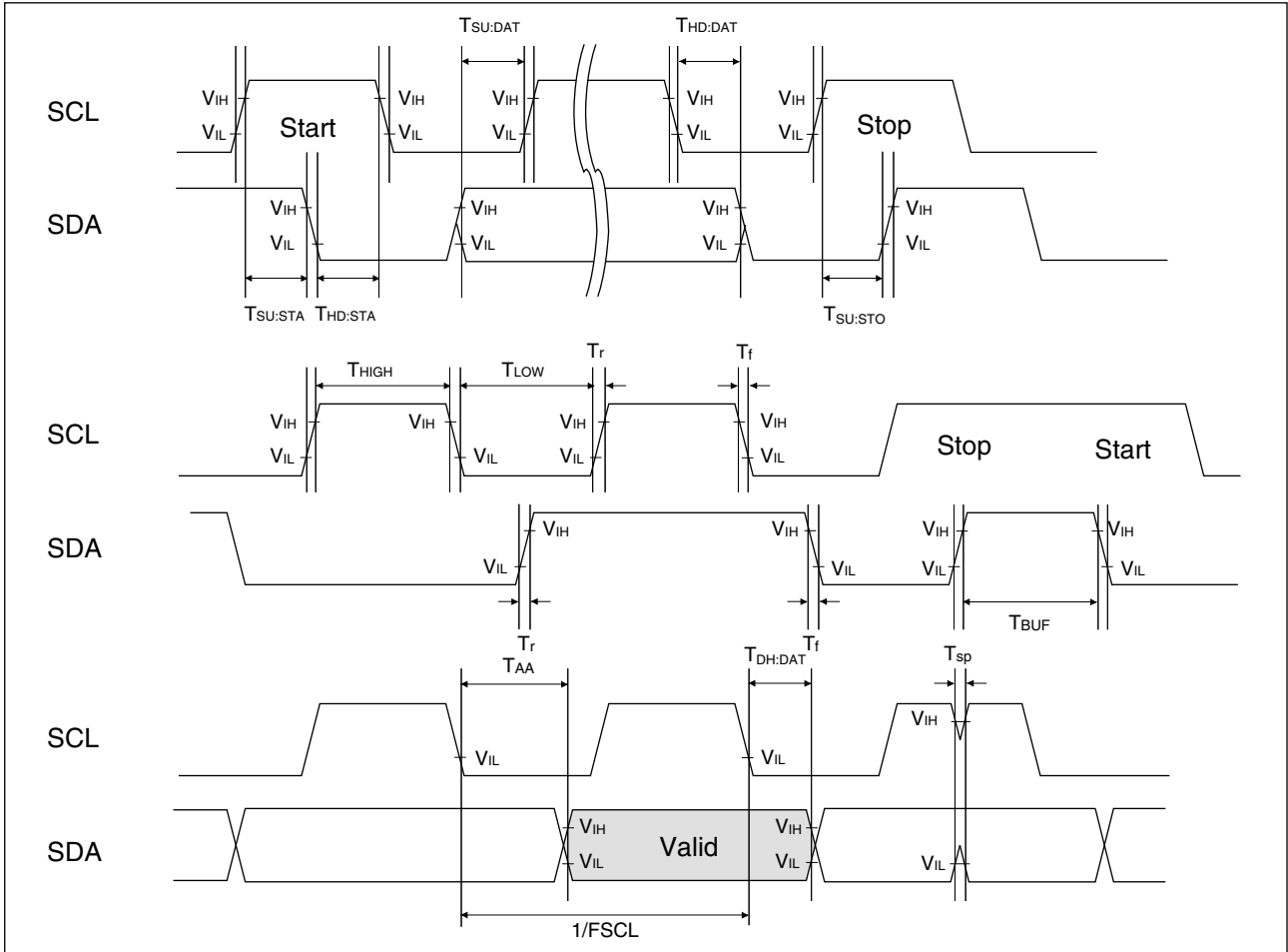

4. Pin Capacitance

Parameter	Symbol	Conditions	Value			Unit
			Min	Typ	Max	
I/O capacitance	$C_{I/O}$	$V_{DD} = 5.0V$, $V_{IN} = V_{OUT} = 0V \sim V_{DD}$, $f = 1\text{ MHz}$, $T_A = +25^\circ\text{C}$	—	—	15	pF
Input capacitance	C_{IN}		—	—	15	pF

5. AC Test Load Circuit

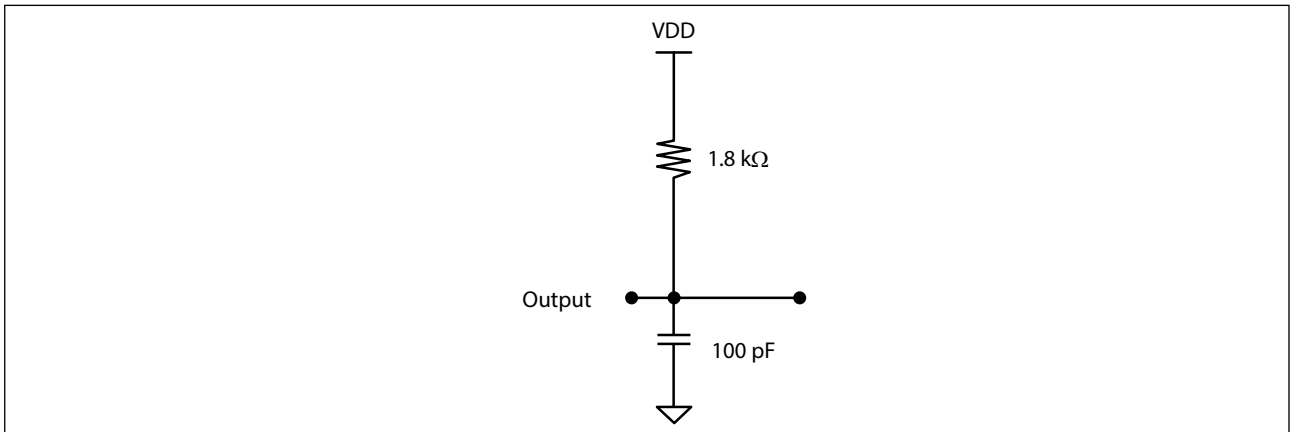

MB85RC64V

■ POWER ON/OFF SEQUENCE

If V_{DD} falls down below 2.0V, V_{DD} is required to be started from 0V to prevent malfunctions when the power is turned on again.

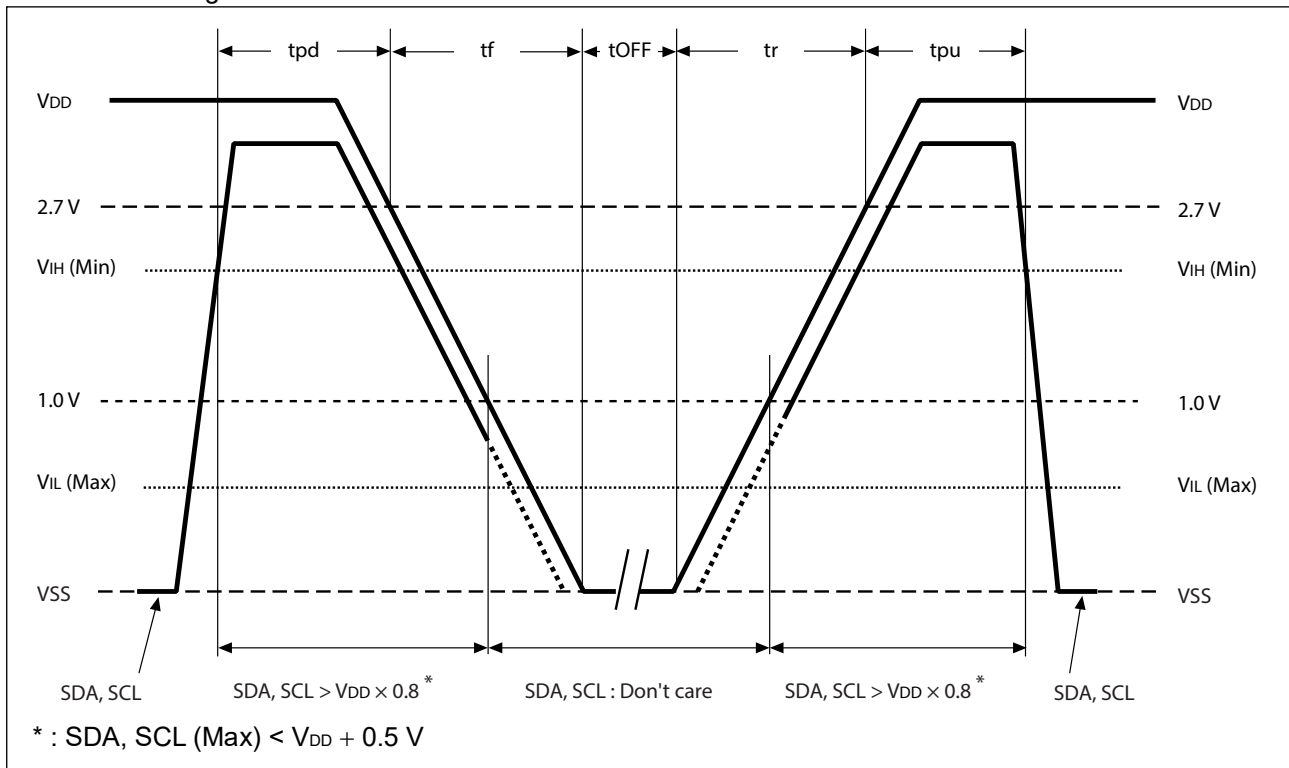

Parameter	Symbol	Value		Unit	Condition
		Min	Max		
SDA, SCL level hold time during power down	tpd	85	—	ns	—
SDA, SCL level hold time during power up	tpu	85	—	ns	$V_{DD} = 5.0V \pm 0.5V$ Operation
		0.5	—	ms	$V_{DD} = 3.3V \pm 0.3V$ Operation
Power supply rising time	tr	0.5	50	ms	$V_{DD} = 5.0V \pm 0.5V$ Operation
		0.005	50		$V_{DD} = 3.3V \pm 0.3V$ Operation
Power supply falling time	tf	0.5	50	ms	—
Power off time	tOFF	50	—	ms	—

If the device does not operate within the specified conditions of read cycle, write cycle or power on/off sequence, memory data can not be guaranteed.

■ FeRAM CHARACTERISTICS

Item	Min	Max	Unit	Parameter
Read/Write Endurance*1	10 ¹²	—	Times/byte	Operation Ambient Temperature T _A = + 85 °C
Data Retention*2	10	—	Years	Operation Ambient Temperature T _A = + 85 °C
	95	—		Operation Ambient Temperature T _A = + 55 °C
	≥ 200	—		Operation Ambient Temperature T _A = + 35 °C

*1 : Total number of reading and writing defines the minimum value of endurance, as an FeRAM memory operates with destructive readout mechanism.

*2 : Minimum values define retention time of the first reading/writing data right after shipment, and these values are calculated by qualification results.

■ NOTE ON USE

- We recommend programming of the device after reflow. Data written before reflow cannot be guaranteed.
- During the access period from the start condition to the stop condition, keep the level of WP, A0, A1 and A2 pins to the “H” level or the “L” level.
- If the time lag between STOP CONDITION and START CONDITION is long, it is rarely but, in some cases, that device will ignore the first START CONDITION. When the device responds with unpredictable signals, execute one of the following from the master side.
 - (1) Software Reset
 - (2) A part of software reset (one start condition and data “1”)
 - (3) Retry the same command (Command Retry)

■ ESD AND LATCH-UP

Test	DUT	Value
ESD HBM (Human Body Model) JESD22-A114 compliant	MB85RC64VPNF-G-JNE1 MB85RC64VPNF-G-JNERE1 MB85RC64VPNF-G-AMERE2 MB85RC64VPNF-G-AME2	$\geq 2000 \text{ V} $
ESD MM (Machine Model) JESD22-A115 compliant		$\geq 200 \text{ V} $
ESD CDM (Charged Device Model) JESD22-C101 compliant		$\geq 1000 \text{ V} $
Latch-Up (C-V Method) Proprietary method		$\geq 200 \text{ V} $

- C-V method of Latch-Up Resistance Test

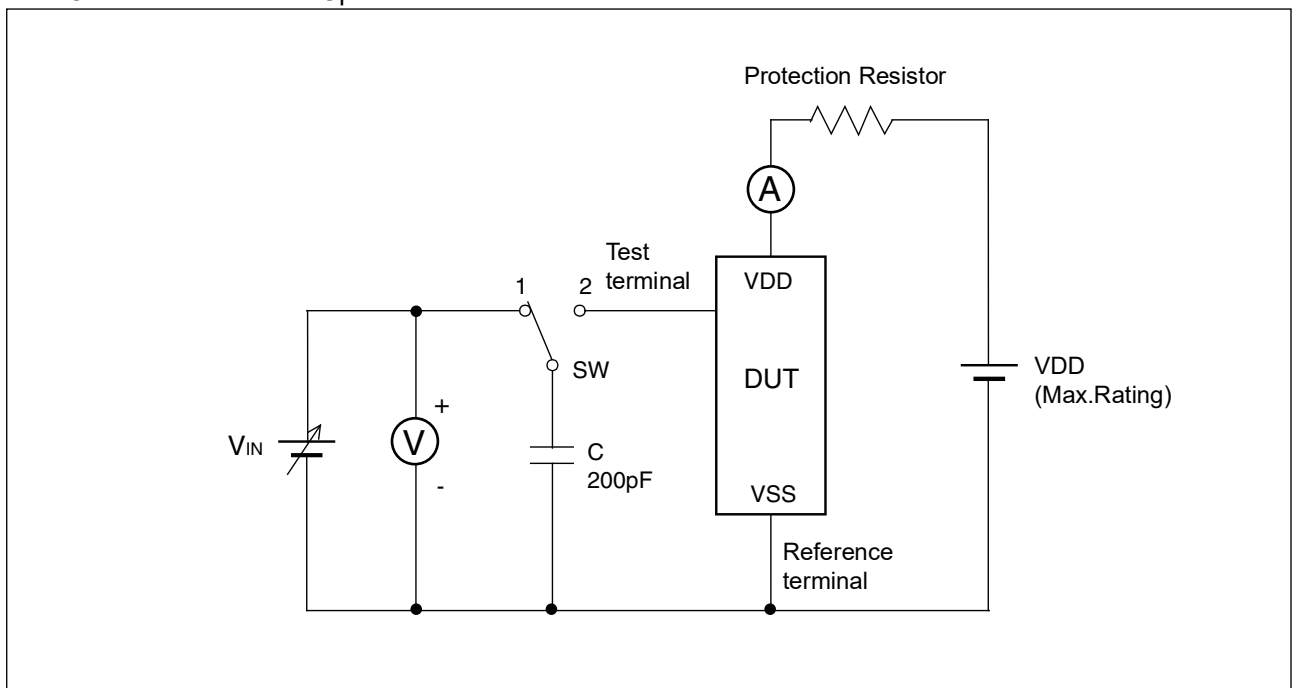

Note : Charge voltage alternately switching 1 and 2 approximately 2 sec interval. This switching process is considered as one cycle.
Repeat this process 5 times. However, if the latch-up condition occurs before completing 5 times, this test must be stopped immediately.

■ REFLOW CONDITIONS AND FLOOR LIFE

[JEDEC MSL] : Moisture Sensitivity Level 1 (IPC/JEDEC J-STD-020E)
MB85RC64VPNF-G-AME2 /MB85RC64VPNF-G-AMERE2

[JEDEC MSL] : Moisture Sensitivity Level 3 (IPC/JEDEC J-STD-020E)
MB85RC64VPNF-G-JNE1 /MB85RC64VPNF-G-JNERE1

■ CURRENT STATUS ON CONTAINED RESTRICTED SUBSTANCES

This product complies with the regulations of REACH Regulations, EU RoHS Directive and China RoHS.

■ ORDERING INFORMATION

Part number	Package	Shipping form	Minimum shipping quantity
MB85RC64VPNF-G-JNE1	8-pin, plastic SOP 150mi	Tube	—*
MB85RC64VPNF-G-JNERE1	8-pin, plastic SOP 150mi	Embossed Carrier tape	1500
MB85RC64VPNF-G-AMERE2	8-pin, plastic SOP 150mi	Embossed Carrier tape	1500
MB85RC64VPNF-G-AME2	8-pin, plastic SOP 150mi	Tube	—*

*: Please contact our sales office about minimum shipping quantity.

MB85RC64V

■ PACKAGE DIMENSION

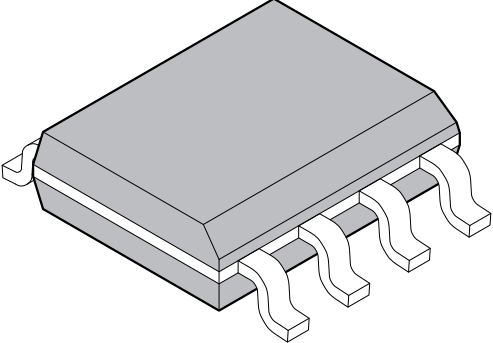
<p>8-pin plastic SOP(150mil)</p> 	Lead pitch	1.27mm	
	Package width x Package length	3.90mm x 4.90mm	
	Lead shape	Gullwing	
	Sealing method	Plastic mold	
	Mounting height	1.75mm MAX.	

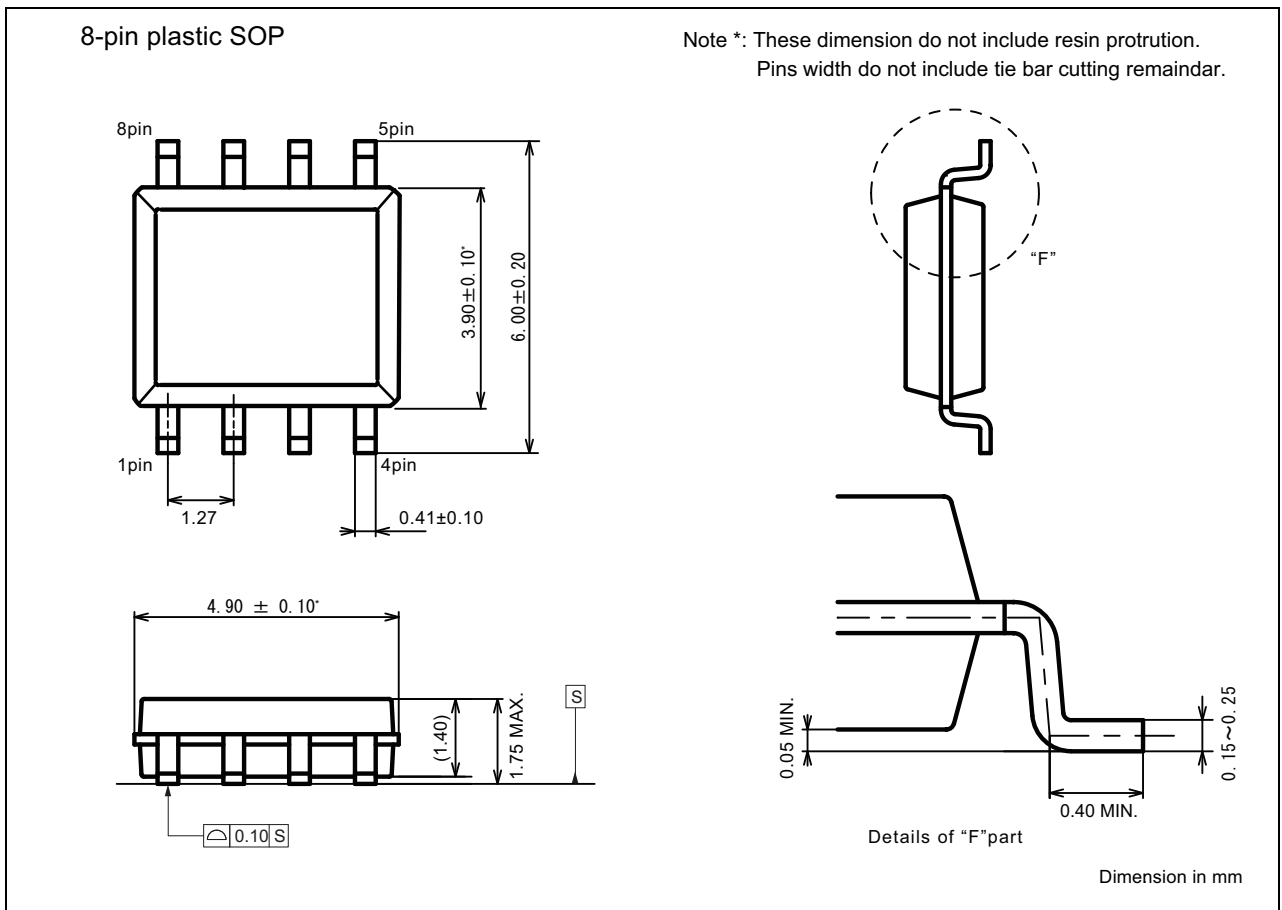

■ MARKING

[MB85RC64VPNF-G-JNE1]
[MB85RC64VPNF-G-JNERE1]



[8-pin plastic SOP 150mil]

RC64V: Product name
E12404: E1(Environmental code) + 2404(Year and Week code)
300: Trace code

[MB85RC64VPNF-G-AME2]
[MB85RC64VPNF-G-AMERE2]

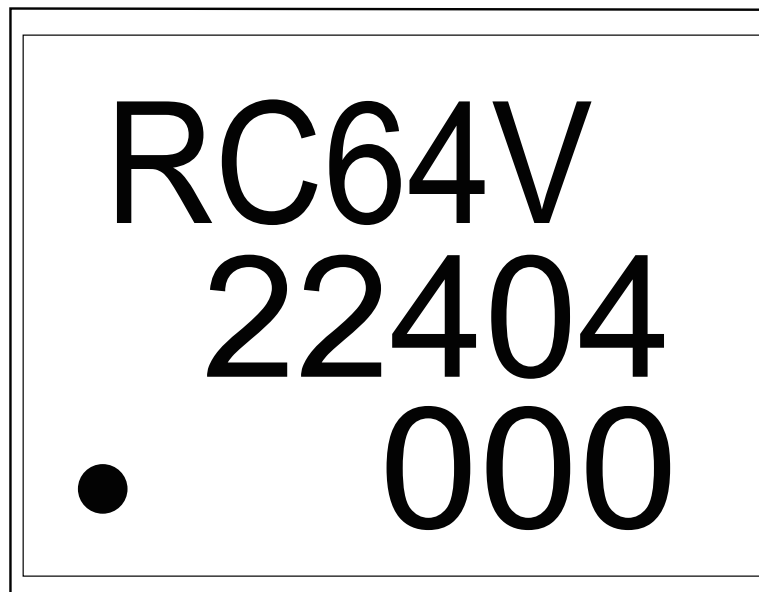

[8-pin plastic SOP 150mil]

RC64V: Product name
22404: 2(Environmental code) + 2404(Year and Week code)
000: Trace code

MB85RC64V

■ PACKING INFORMATION

1. Tube (MB85RC64VPNF-G-JNE1)

1.1 Tube Dimensions

- Tube/stopper shape (example)

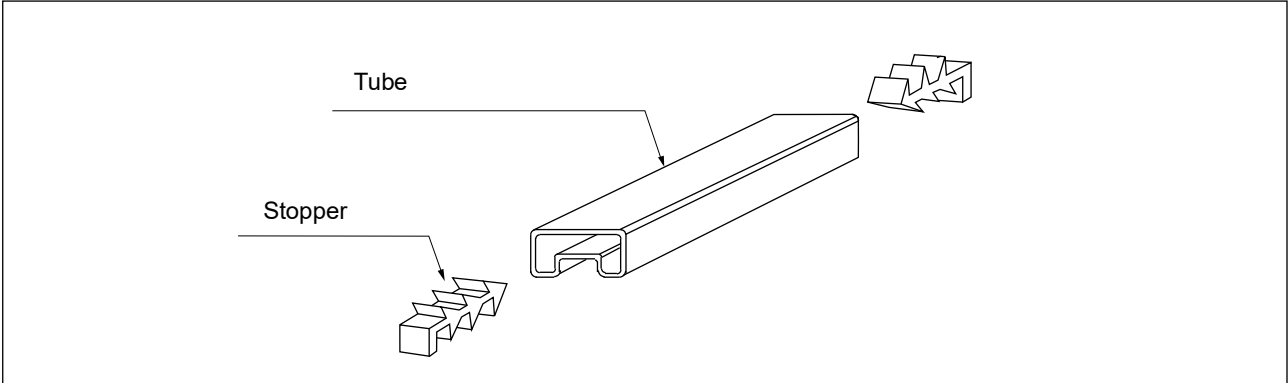

- Tube cross-sections and Maximum quantity

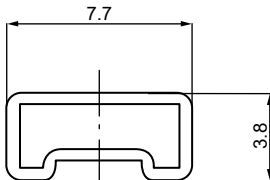
MB85RC64VPNF-G-JNE1 	Maximum quantity		
	ICs/tube	ICs/inner box	ICs/outer box
	95	7,600	30,400

tube length:521

No heat resistance.
Package should not be baked by using tube.

(Dimensions in mm)

- Direction of index in tube

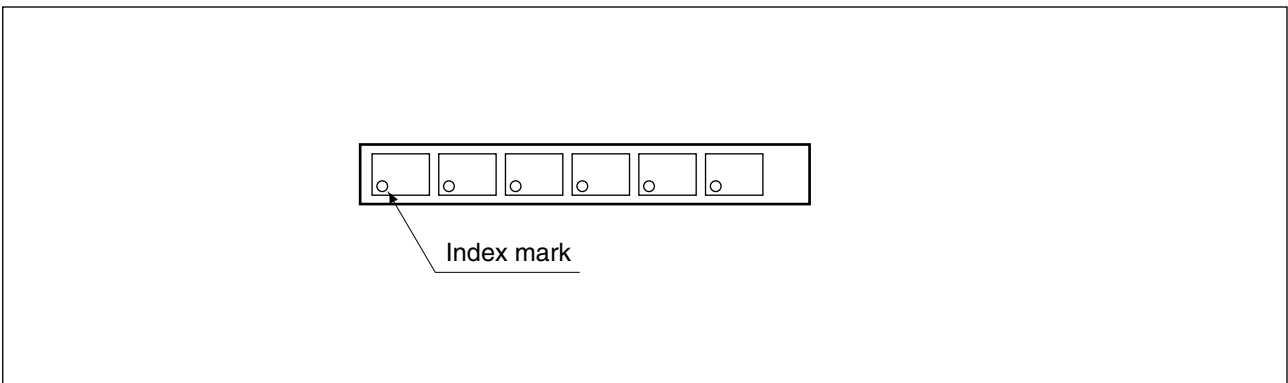

1.2 Product label indicators (an example)

Label I: Label on Inner box/Moisture Barrier Bag/ (It sticks it on the reel for the emboss taping)
 [C-3 Label (50mm × 100mm) Supplemental Label (20mm × 100mm)]

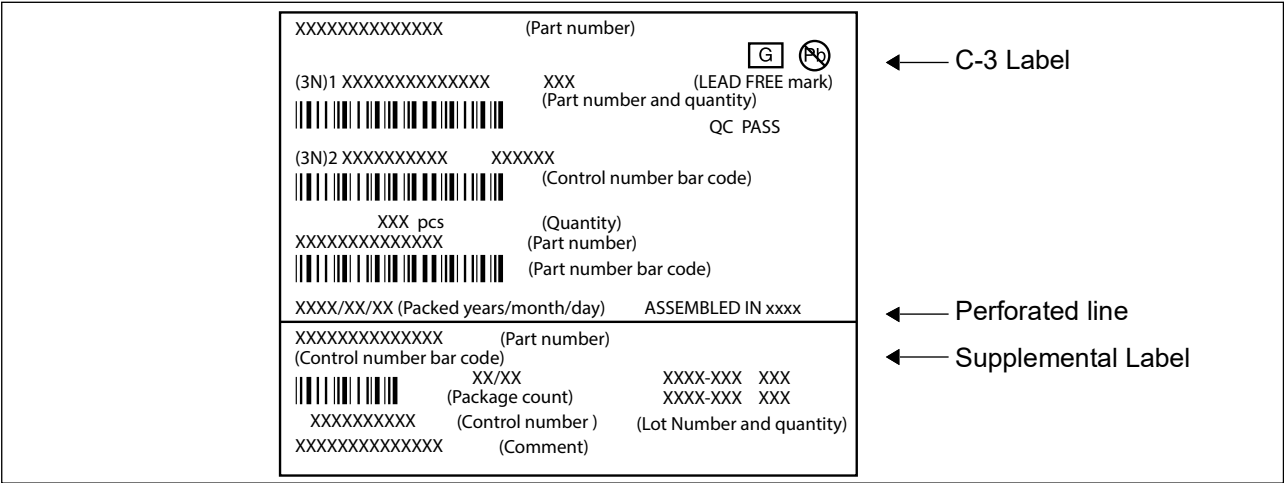

MB85RC64V

1.3 Dimensions for Containers

(1) Dimensions for inner box

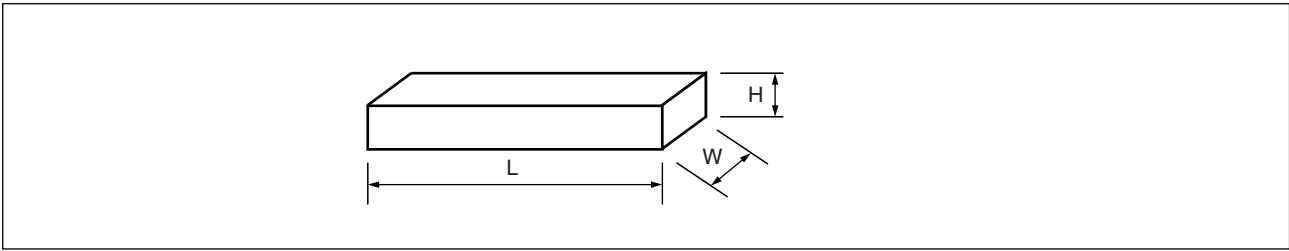

L	W	H
540	125	75

(Dimensions in mm)

(2) Dimensions for outer box

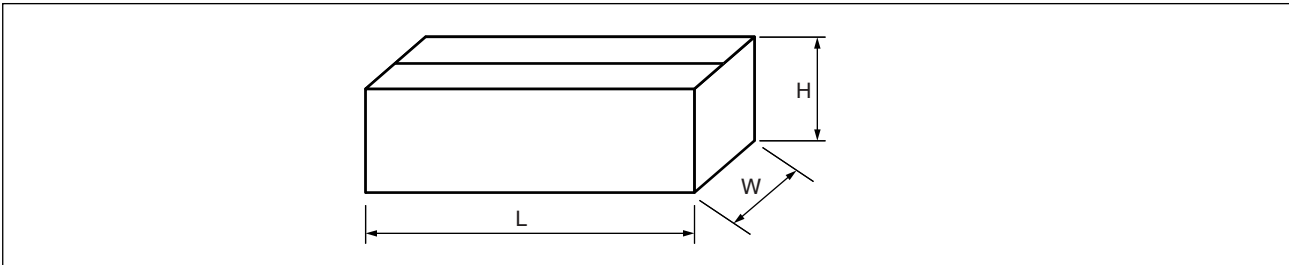

L	W	H
565	270	180

(Dimensions in mm)

2. Emboss Tape(MB85RC64VPNF-G-JNERE1/MB85RC64VPNF-G-AMERE2)

2.1 Tape Dimensions (not drawn to scale)(8-pin plastic SOP 150mil)

Part number	reel diameter (mm)	Maximum storage capacity		
		ICs/ reel	ICs/inner box	ICs/outer box
MB85RC64VPNF-G-JNERE1	φ330	1,500	1,500 (1 pack/inner box)	10,500 (7 inner boxes/ outer box:Max.)
MB85RC64VPNF-G-AMERE2	φ254	1,500	1,500 (1 pack/inner box)	9,000 (6 inner boxes/ outer box:Max.)

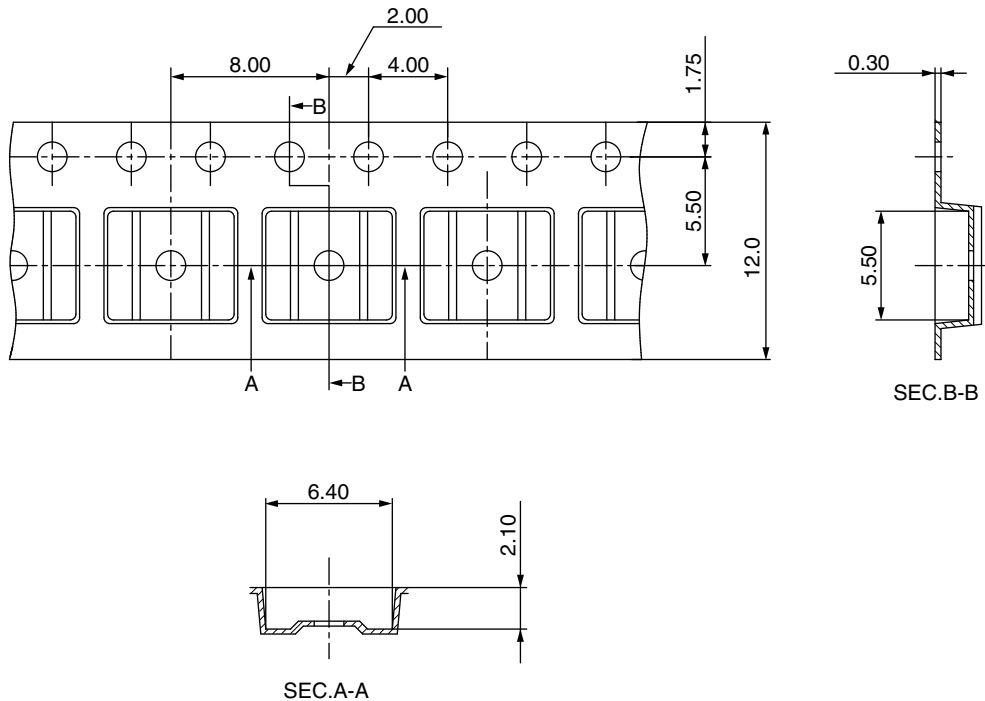

(Dimensions in mm)

Heat proof temperature : No heat resistance.

Package should not be baked by using
tape and reel.

MB85RC64V

2.2 IC orientation

8-pin plastic SOP 150mil

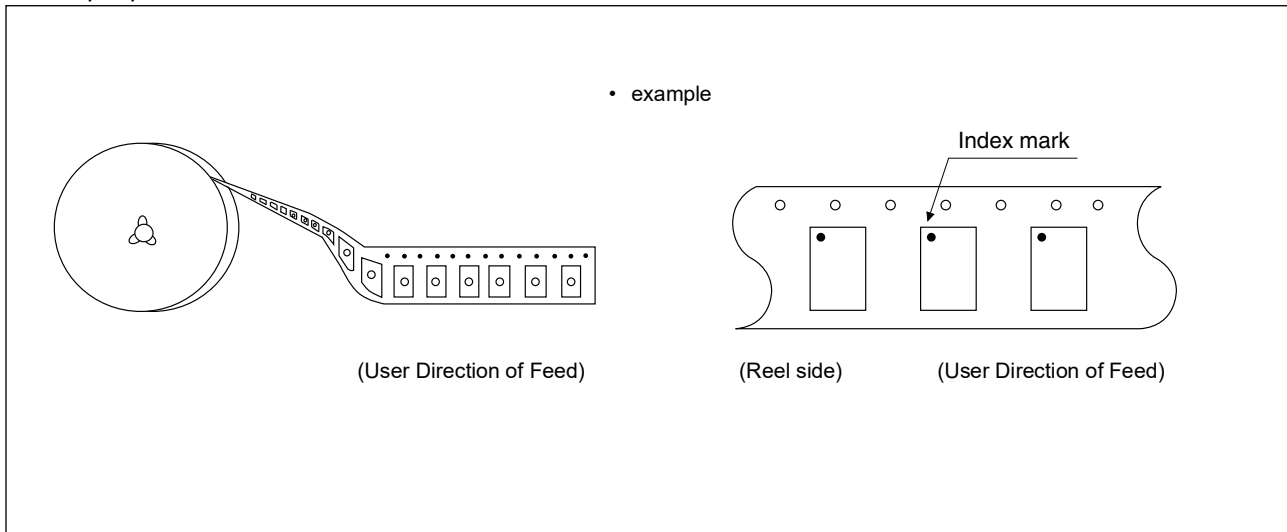

2.3 Reel dimensions

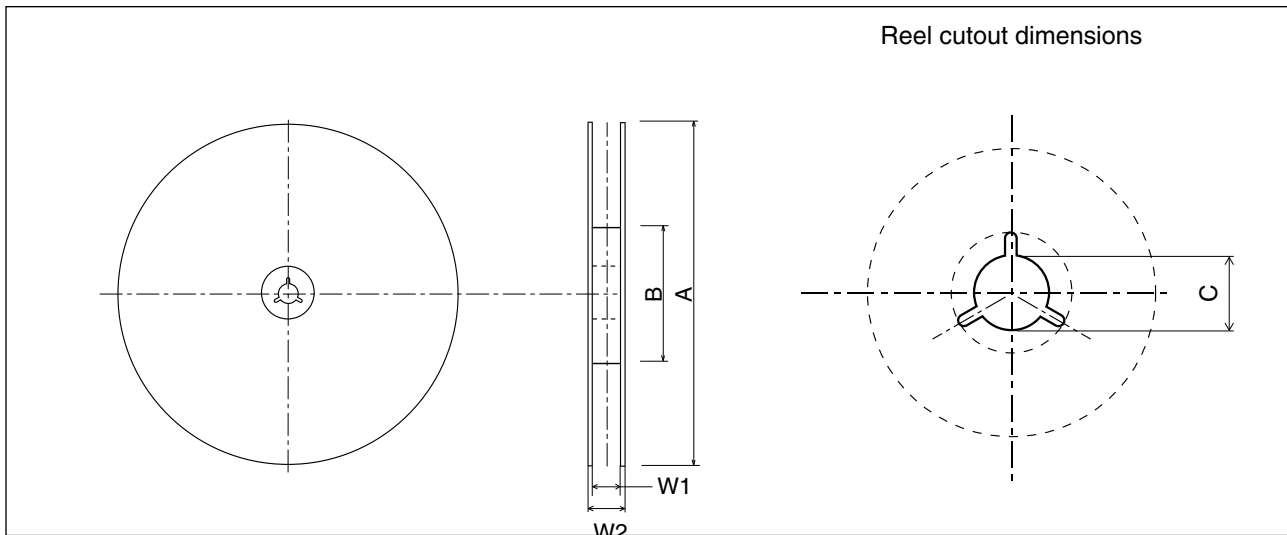

Dimensions in mm

Part number	A	B	C	W1	W2
MB85RC64VPNF-G-JNERE1	330	100	13	12.4	17.2
MB85RC64VPNF-G-AMERE2	254	100	13	13.5	17.5

2.4 Product label indicators (an example)

Label I: Label on Inner box/Moisture Barrier Bag/ (It sticks it on the reel for the emboss taping)
[C-3 Label (50mm × 100mm) Supplemental Label (20mm × 100mm)]

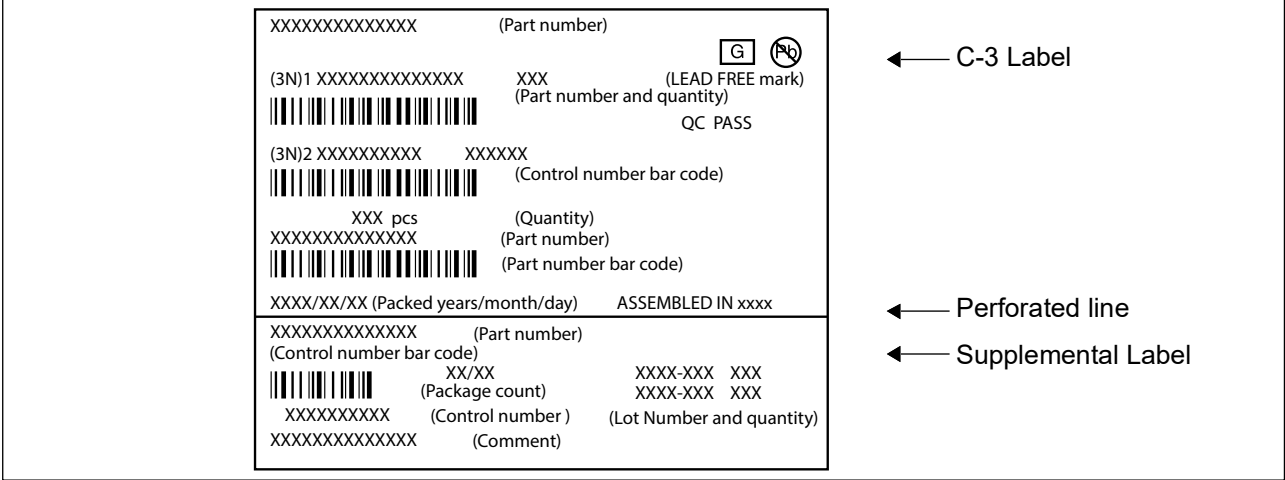

MB85RC64V

2.5 Dimensions for Containers

(1) Dimensions for inner box

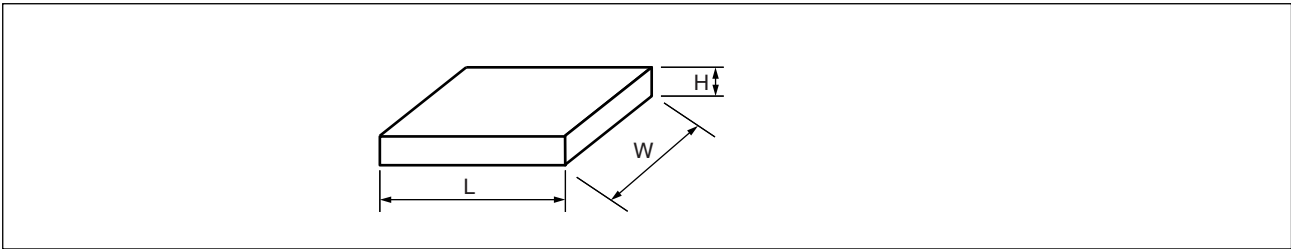

Part number	L	W	H
MB85RC64VPNF-G-JNERE1	365	345	40
MB85RC64VPNF-G-AMERE2	265	260	50

(Dimensions in mm)

(2) Dimensions for outer box

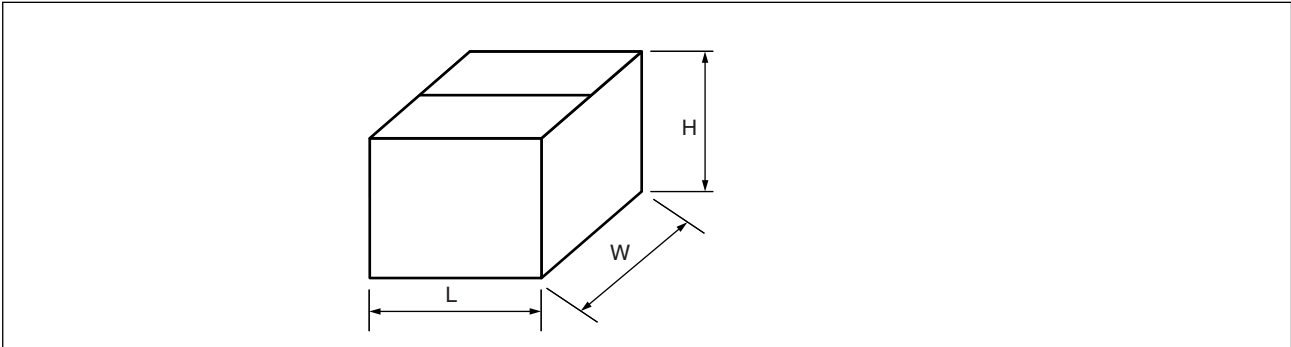

Part number	L	W	H
MB85RC64VPNF-G-JNERE1	415	400	315
MB85RC64VPNF-G-AMERE2	565	270	180

(Dimensions in mm)

3.5 Dimensions for Containers

(1) Dimensions for inner box

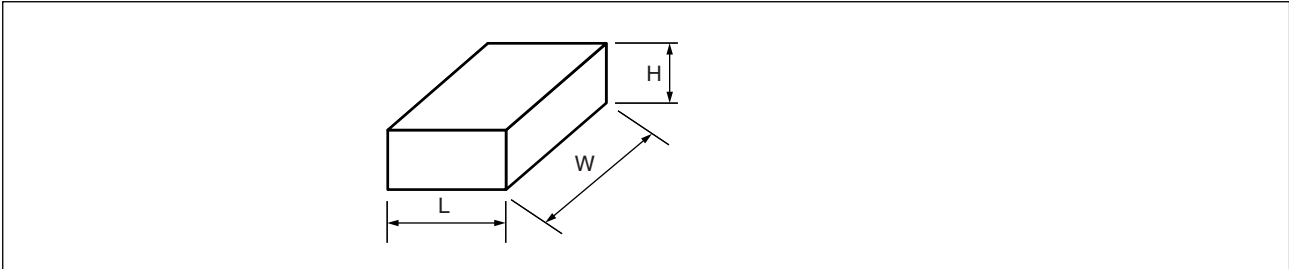

L	W	H
165	360	75

(Dimensions in mm)

(2) Dimensions for outer box

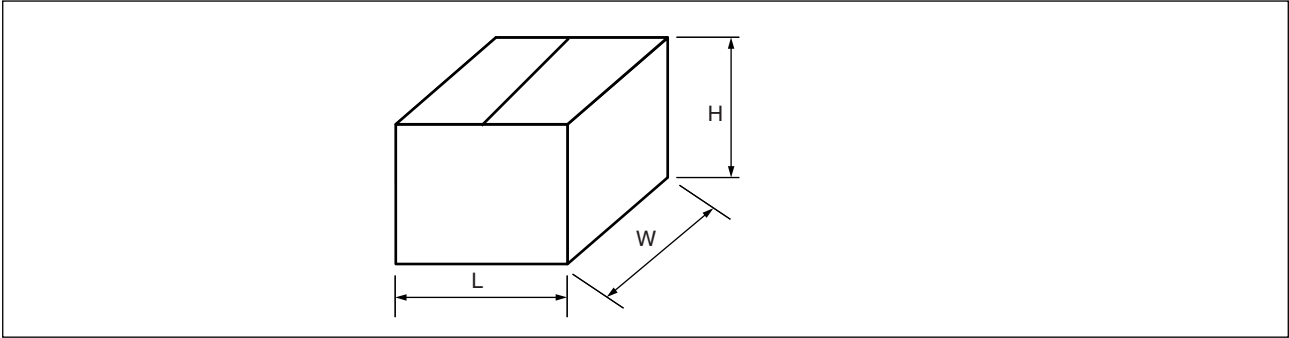

L	W	H
355	385	195

(Dimensions in mm)

■ MAJOR CHANGES IN THIS EDITION

A change on a page is indicated by a vertical line drawn on the left side of that page.

Page	Section	Results
13	Pin capacitance	Update about "Conditions".
16	REFLOW CONDITIONS AND FLOOR LIFE	Add Moisture Sensitivity Level 1.

MB85RC64V

RAMXEED LIMITED

Shin-Yokohama Chuo Building, 2-100-45 Shin-Yokohama,
Kohoku-ku, Yokohama, Kanagawa 222-0033, Japan
<https://ramxeed.com/>

All Rights Reserved.

RAMXEED LIMITED, its subsidiaries and affiliates (collectively, "RAMXEED") reserves the right to make changes to the information contained in this document without notice. Please contact your RAMXEED sales representatives before order of RAMXEED device.

Information contained in this document, such as descriptions of function and application circuit examples is presented solely for reference to examples of operations and uses of RAMXEED device. RAMXEED disclaims any and all warranties of any kind, whether express or implied, related to such information, including, without limitation, quality, accuracy, performance, proper operation of the device or non-infringement. If you develop equipment or product incorporating the RAMXEED device based on such information, you must assume any responsibility or liability arising out of or in connection with such information or any use thereof. RAMXEED assumes no responsibility or liability for any damages whatsoever arising out of or in connection with such information or any use thereof.

Nothing contained in this document shall be construed as granting or conferring any right under any patents, copyrights, or any other intellectual property rights of RAMXEED or any third party by license or otherwise, express or implied. RAMXEED assumes no responsibility or liability for any infringement of any intellectual property rights or other rights of third parties resulting from or in connection with the information contained herein or use thereof.

The products described in this document are designed, developed and manufactured as contemplated for general use including without limitation, ordinary industrial use, general office use, personal use, and household use, but are not designed, developed and manufactured as contemplated (1) for use accompanying fatal risks or dangers that, unless extremely high levels of safety is secured, could lead directly to death, personal injury, severe physical damage or other loss (including, without limitation, use in nuclear facility, aircraft flight control system, air traffic control system, mass transport control system, medical life support system and military application), or (2) for use requiring extremely high level of reliability (including, without limitation, submersible repeater and artificial satellite). RAMXEED shall not be liable for you and/or any third party for any claims or damages arising out of or in connection with above-mentioned uses of the products.

Any semiconductor devices fail or malfunction with some probability. You are responsible for providing adequate designs and safeguards against injury, damage or loss from such failures or malfunctions, by incorporating safety design measures into your facility, equipments and products such as redundancy, fire protection, and prevention of overcurrent levels and other abnormal operating conditions.

The products and technical information described in this document are subject to the Foreign Exchange and Foreign Trade Control Law of Japan, and may be subject to export or import laws or regulations in U.S. or other countries. You are responsible for ensuring compliance with such laws and regulations relating to export or re-export of the products and technical information described herein. All company names, brand names and trademarks herein are property of their respective owners.