

Memory FeRAM

64 K (8 K × 8) Bit SPI

MB85RS64

■ DESCRIPTION

MB85RS64 is a FeRAM (Ferroelectric Random Access Memory) chip in a configuration of 8,192 words × 8 bits, using the ferroelectric process and silicon gate CMOS process technologies for forming the nonvolatile memory cells.

MB85RS64 adopts the Serial Peripheral Interface (SPI).

The MB85RS64 is able to retain data without using a back-up battery, as is needed for SRAM.

The memory cells used in the MB85RS64 can be used for 10^{12} read/write operations, which is a significant improvement over the number of read and write operations supported by Flash memory and E²PROM.

MB85RS64 does not take long time to write data like Flash memories or E²PROM, and MB85RS64 takes no wait time.

■ FEATURES

- Bit configuration : 8,192 words × 8 bits
- Serial Peripheral Interface : SPI (Serial Peripheral Interface)
Correspondent to SPI mode 0 (0, 0) and mode 3 (1, 1)
- Operating frequency : 20 MHz (Max)
- High endurance : 10^{12} times / byte
- Data retention : 10 years (+ 85 °C), 95 years (+ 55 °C), over 200 years (+ 35 °C)
- Operating power supply voltage : 2.7 V to 3.6 V
- Low power consumption : Operating power supply current 1.5 mA (Typ@20 MHz)
Standby current 5 μA (Typ)
- Operation ambient temperature range : - 40 °C to +85 °C
- Package : 8-pin plastic SOP RoHS compliant

Fujitsu Semiconductor Memory Solutions Limited has changed its name to RAMXEED Limited. RAMXEED Limited will continue to offer and support existing products while maintaining Fujitsu's part number unchanged.

■ PIN ASSIGNMENT

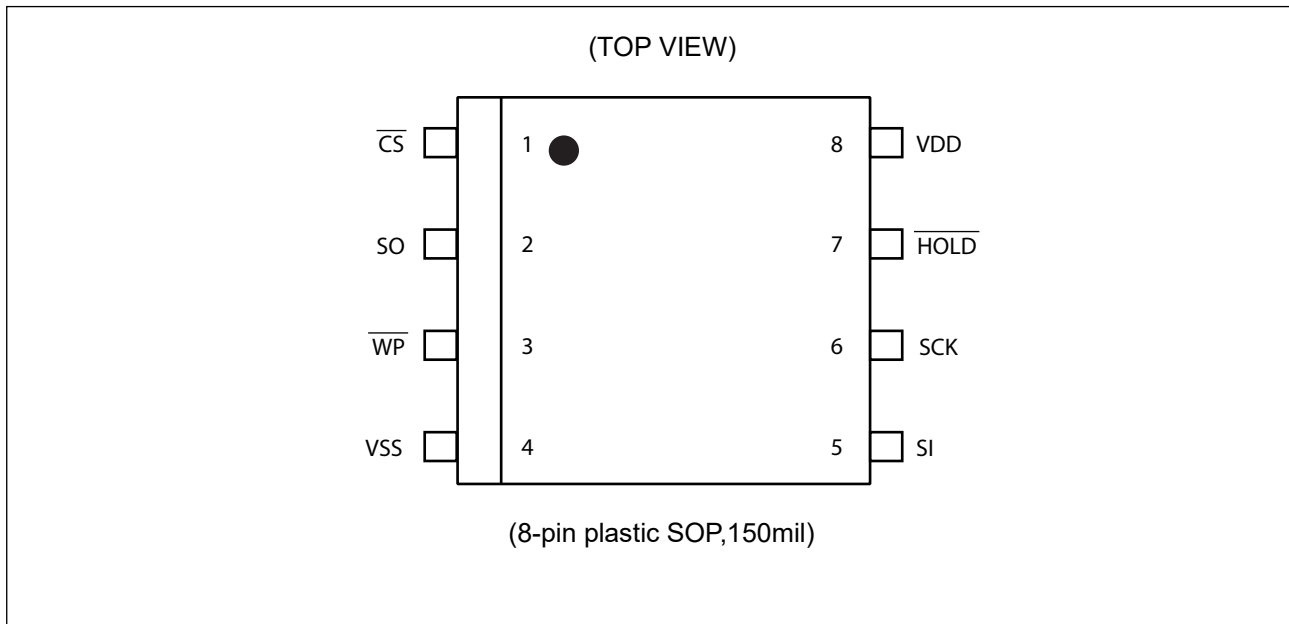

■ PIN FUNCTIONAL DESCRIPTIONS

Pin No.	Pin Name	Functional description
1	\overline{CS}	Chip Select pin This is an input pin to make chip select. When \overline{CS} is the "H" level, device is in deselect (standby) status and SO becomes High-Z. Inputs from other pins are ignored at this time. When \overline{CS} is the "L" level, device is in select (active) status. \overline{CS} has to be the "L" level before inputting op-code. The Chip Select pin is pulled up internally to the VDD pin.
3	\overline{WP}	Write Protect pin This is a pin to control writing to a status register. The writing of status register (see "■ STATUS REGISTER") is protected in related with \overline{WP} and WPEN. See "■ WRITING PROTECT" for detail.
7	\overline{HOLD}	Hold pin This pin is used to interrupt serial input/output without making chip deselect. When \overline{HOLD} is the "L" level, hold operation is activated, SO becomes High-Z, and SCK and SI become don't care. While the hold operation, \overline{CS} shall be retained the "L" level.
6	SCK	Serial Clock pin This is a clock input pin to input/output serial data. SI is loaded synchronously to a rising edge, SO is output synchronously to a falling edge.
5	SI	Serial Data Input pin This is an input pin of serial data. This inputs op-code, address, and writing data.
2	SO	Serial Data Output pin This is an output pin of serial data. Reading data of FeRAM memory cell array and status register are output. This is High-Z during standby.
8	VDD	Supply Voltage pin
4	VSS	Ground pin

■ BLOCK DIAGRAM

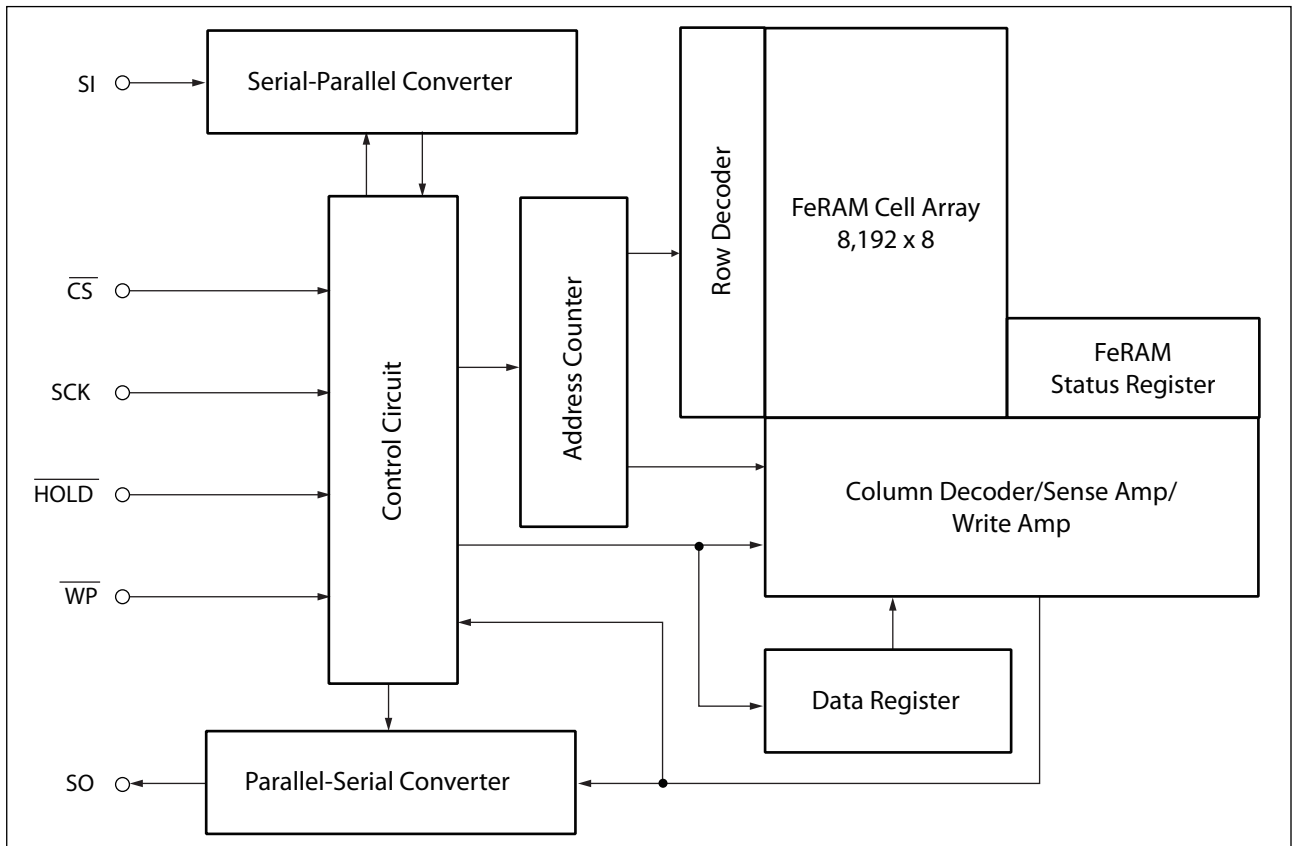

■ SPI MODE

MB85RS64 corresponds to the SPI mode 0 (CPOL = 0, CPHA = 0), and SPI mode 3 (CPOL = 1, CPHA = 1).

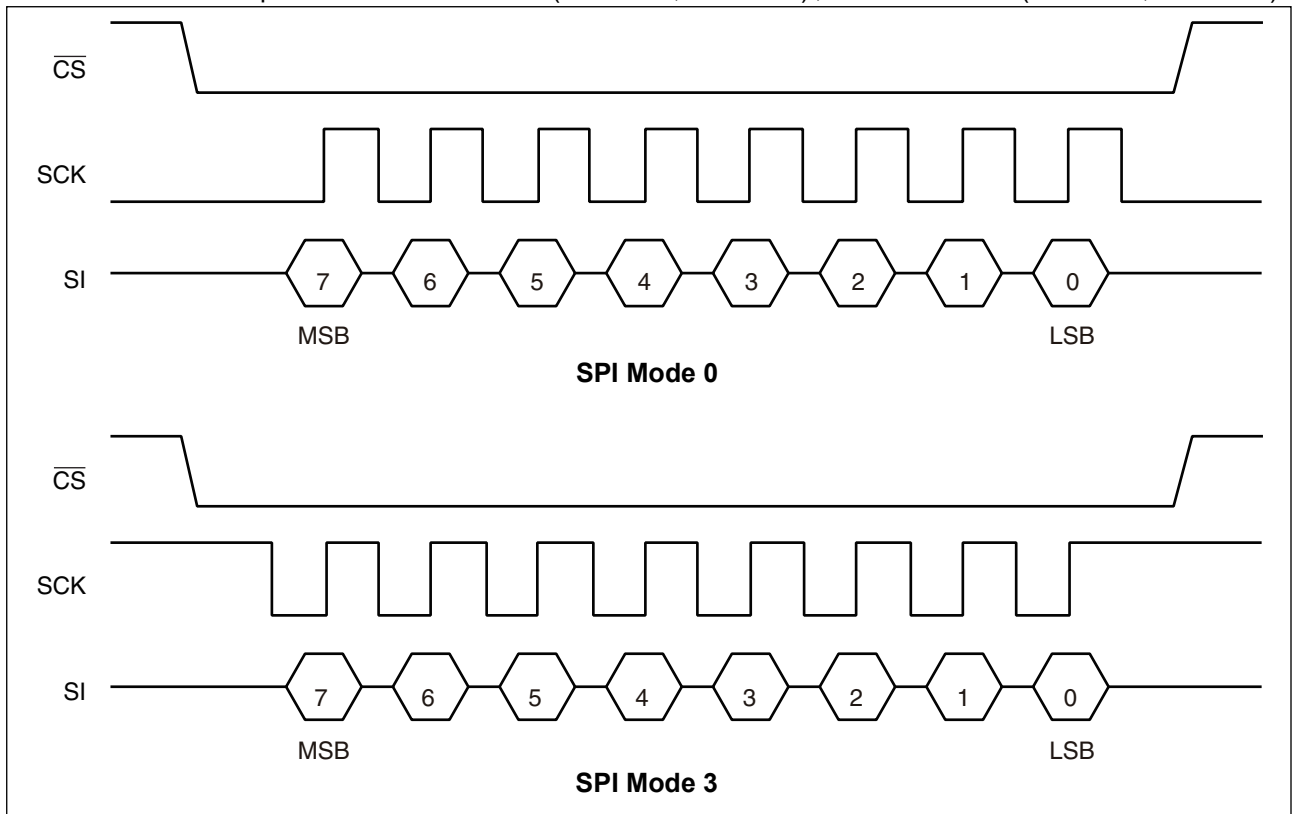

■ SERIAL PERIPHERAL INTERFACE (SPI)

MB85RS64 works as a slave of SPI. More than 2 devices can be connected by using microcontroller equipped with SPI port. By using a microcontroller not equipped with SPI port, SI and SO can be bus connected to use.

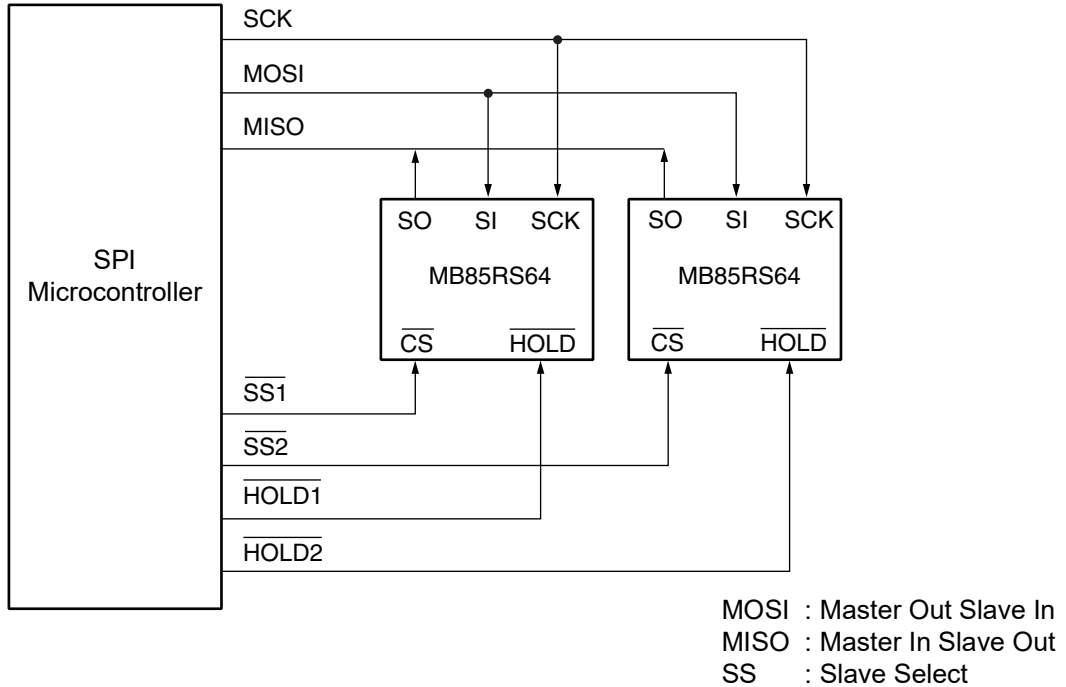

System Configuration with SPI Port

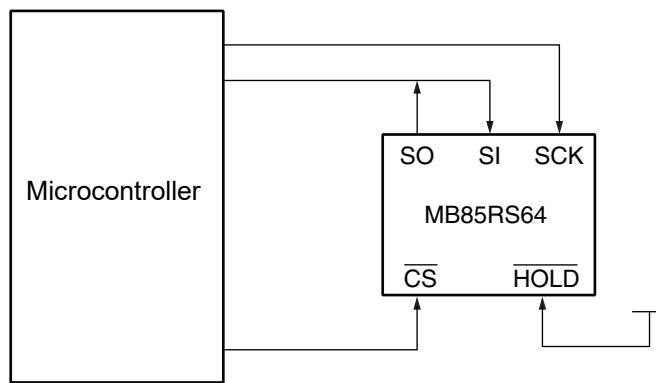

System Configuration without SPI Port

■ STATUS REGISTER

Bit No.	Bit Name	Function
7	WPEN	Status Register Write Protect This is a bit composed of nonvolatile memories (FeRAM). WPEN protects writing to a status register (see “■ WRITING PROTECT”) relating with \overline{WP} input. Writing with the WRSR command and reading with the RDSR command are possible.
6 to 4	—	Not Used Bits These are bits composed of nonvolatile memories, writing with the WRSR command is possible, and “000” is written before shipment. These bits are not used but they are read with the RDSR command.
3	BP1	Block Protect This is a bit composed of nonvolatile memory. This defines size of write protect block for the WRITE command (see “■ BLOCK PROTECT”). Writing with the WRSR command and reading with the RDSR command are possible.
2	BP0	
1	WEL	Write Enable Latch This indicates FeRAM Array and status register are writable. The WREN command is for setting, and the WRDI command is for resetting. With the RDSR command, reading is possible but writing is not possible with the WRSR command. WEL is reset after the following operations. After power ON. After WRDI command recognition. At the rising edge of \overline{CS} after WRSR command recognition. At the rising edge of \overline{CS} after WRITE command recognition.
0	0	This is a bit fixed to “0”.

■ OP-CODE

MB85RS64 accepts 6 kinds of command specified in op-code. Op-code is a code composed of 8 bits shown in the table below. Do not input invalid codes other than those codes. If \overline{CS} is risen while inputting op-code, the command are not performed.

Name	Description	Op-code
WREN	Set Write Enable Latch	0000 0110 _B
WRDI	Reset Write Enable Latch	0000 0100 _B
RDSR	Read Status Register	0000 0101 _B
WRSR	Write Status Register	0000 0001 _B
READ	Read Memory Code	0000 0011 _B
WRITE	Write Memory Code	0000 0010 _B

MB85RS64

■ COMMAND

• WREN

The WREN command sets WEL (Write Enable Latch) . WEL shall be set with the WREN command before writing operation (WRSR command and WRITE command) .

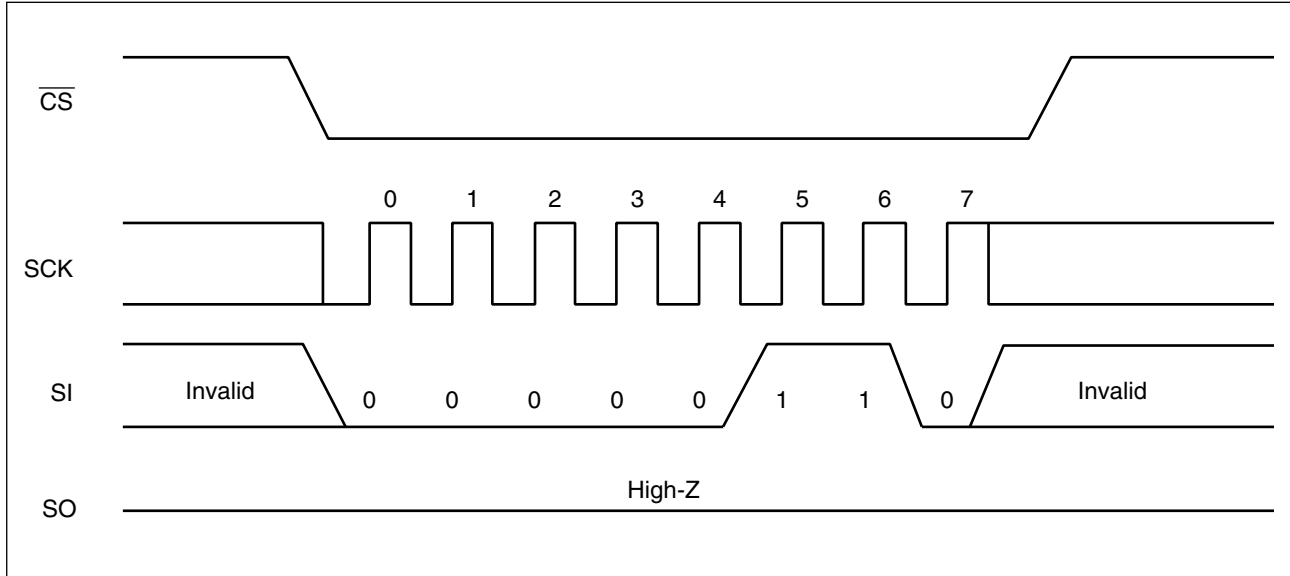

• WRDI

The WRDI command resets WEL (Write Enable Latch) . Writing operation (WRITE command and WRSR command) are not performed when WEL is reset.

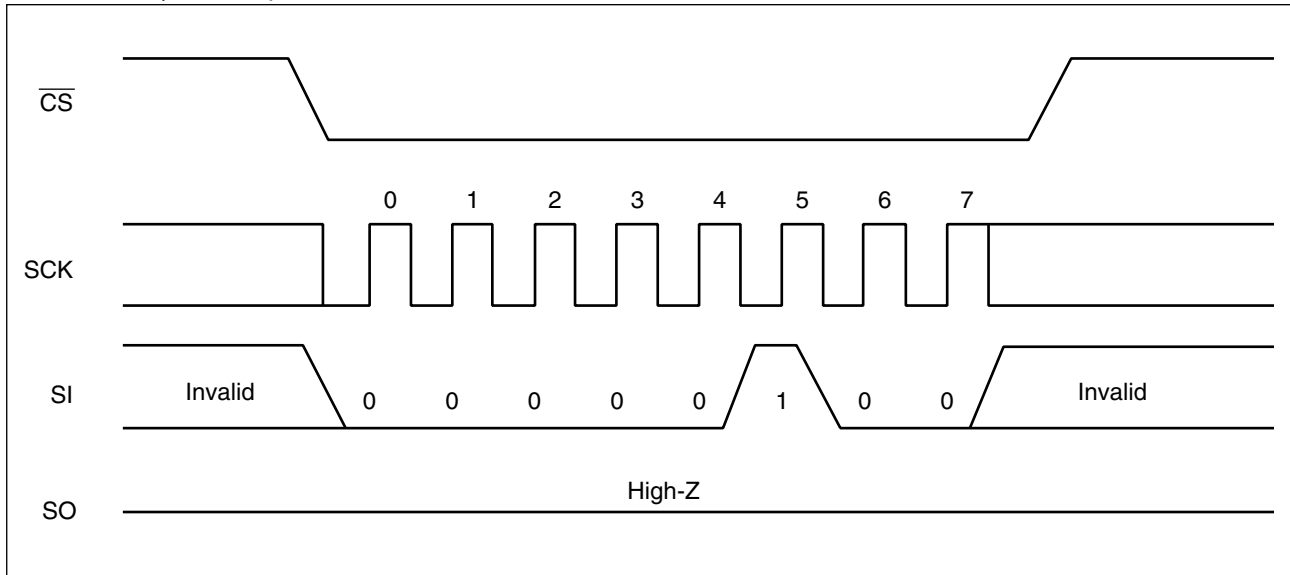

• RDSR

The RDSR command reads status register data. After op-code of RDSR is input to SI, 8-cycle clock is input to SCK. The SI value is invalid during this time. SO is output synchronously to a falling edge of SCK. In the RDSR command, repeated reading of status register is enabled by sending SCK continuously before rising of \overline{CS} .

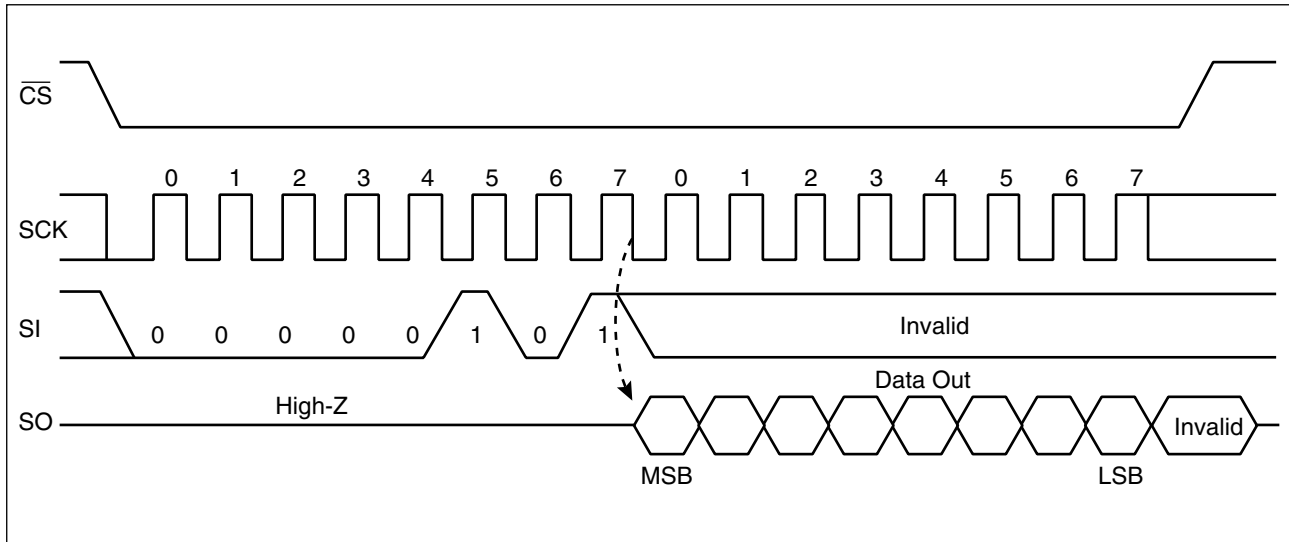

• WRSR

The WRSR command writes data to the nonvolatile memory bit of status register. After performing WRSR op-code to a SI pin, 8 bits writing data is input. WEL (Write Enable Latch) is not able to be written with WRSR command. A SI value correspondent to bit 1 is ignored. Bit 0 of the status register is fixed to "0" and cannot be written. The SI value corresponding to bit 0 is ignored. The \overline{WP} signal level shall be fixed before performing the WRSR command, and do not change the \overline{WP} signal level until the end of command sequence.

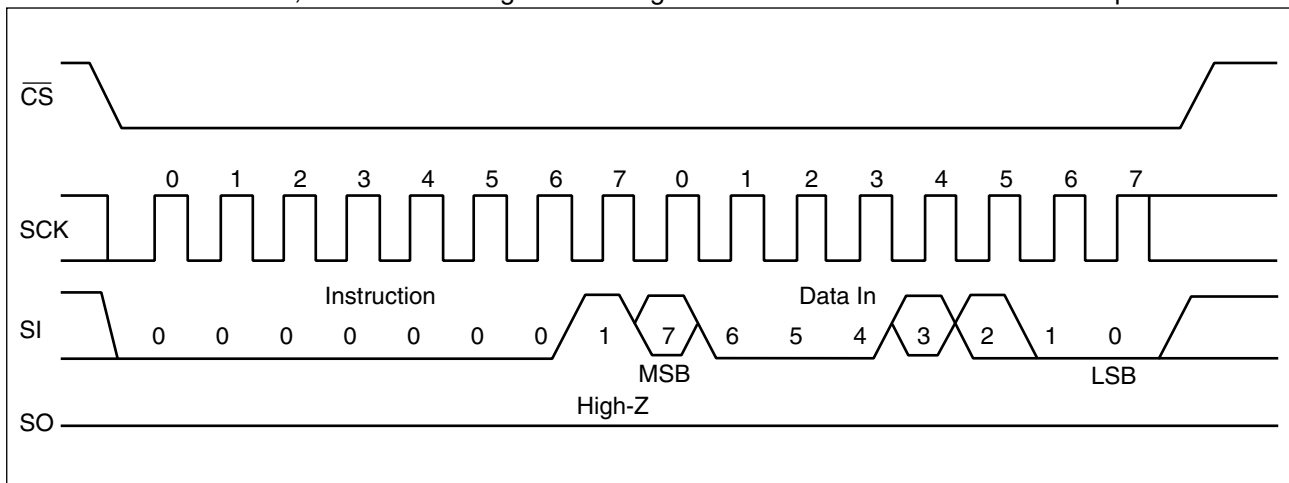

MB85RS64

• READ

The READ command reads FeRAM memory cell array data. Arbitrary 16 bits address and op-code of READ are input to SI. The 3-bit upper address bit is invalid. Then, 8-cycle clock is input to SCK. SO is output synchronously to the falling edge of SCK. While reading, the SI value is invalid. When \overline{CS} is risen, the READ command is completed, but keeps on reading with automatic address increment which is enabled by continuously sending clocks to SCK in unit of 8 cycles before \overline{CS} rising. When it reaches the most significant address, it rolls over to the starting address, and reading cycle keeps on infinitely.

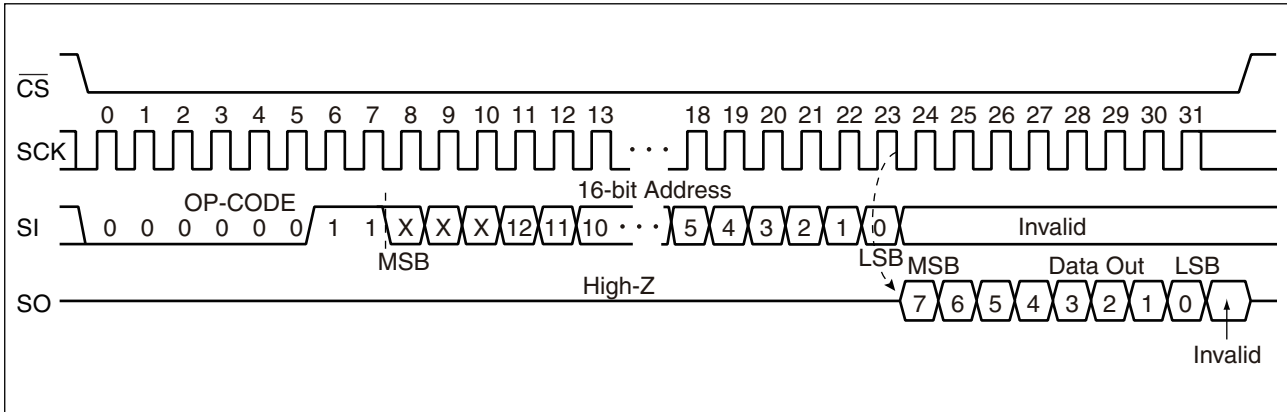

• WRITE

The WRITE command writes data to FeRAM memory cell array. WRITE op-code, arbitrary 16 bits of address and 8 bits of writing data are input to SI. The 3-bit upper address bit is invalid. When 8 bits of writing data is input, data is written to FeRAM memory cell array. Risen \overline{CS} will terminate the WRITE command. However, if you continue sending the writing data for 8 bits each before \overline{CS} rising, it is possible to continue writing with automatic address increment. When it reaches the most significant address, it rolls over to the starting address, and writing cycle keeps on continued infinitely.

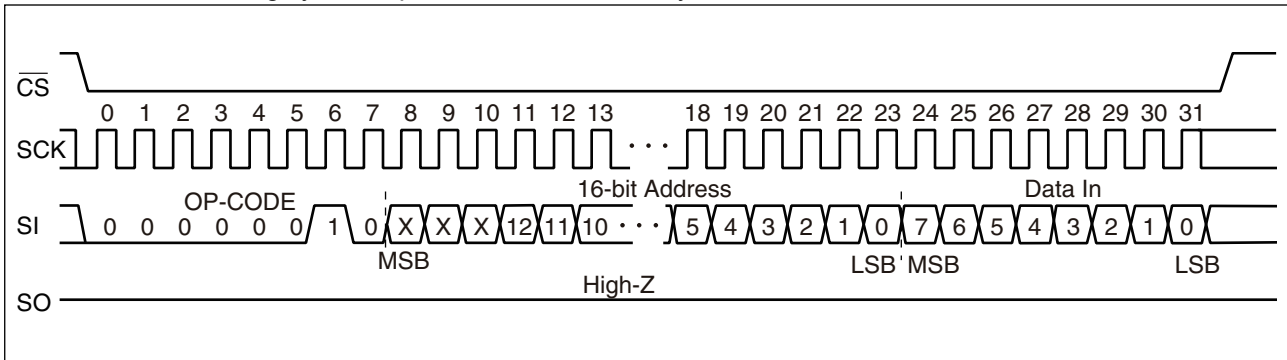

■ BLOCK PROTECT

Writing protect block for WRITE command is configured by the value of BP0 and BP1 in the status register.

BP1	BP0	Protected Block
0	0	None
0	1	1800 _H to 1FFF _H (upper 1/4)
1	0	1000 _H to 1FFF _H (upper 1/2)
1	1	0000 _H to 1FFF _H (all)

■ WRITING PROTECT

Writing operation of the WRITE command and the WRSR command are protected with the value of WEL, WPEN, WP as shown in the table.

WEL	WPEN	WP	Protected Blocks	Unprotected Blocks	Status Register
0	X	X	Protected	Protected	Protected
1	0	X	Protected	Unprotected	Unprotected
1	1	0	Protected	Unprotected	Protected
1	1	1	Protected	Unprotected	Unprotected

■ HOLD OPERATION

Hold status is retained without aborting a command if $\overline{\text{HOLD}}$ is the "L" level while $\overline{\text{CS}}$ is the "L" level. The timing for starting and ending hold status depends on the SCK to be the "H" level or the "L" level when a HOLD pin input is transitioned to the hold condition as shown in the diagram below. In case the $\overline{\text{HOLD}}$ pin transitioned to "L" level when SCK is "L" level, return the $\overline{\text{HOLD}}$ pin to "H" level at SCK being "L" level. In the same manner, in case the $\overline{\text{HOLD}}$ pin transitioned to "L" level when SCK is "H" level, return the $\overline{\text{HOLD}}$ pin to "H" level at SCK being "H" level. Arbitrary command operation is interrupted in hold status, SCK and SI inputs become don't care. And, SO becomes High-Z while reading command (RDSR, READ). If $\overline{\text{CS}}$ is rising during hold status, a command is aborted. In case the command is aborted before its recognition, WEL holds the value before transition to hold status.

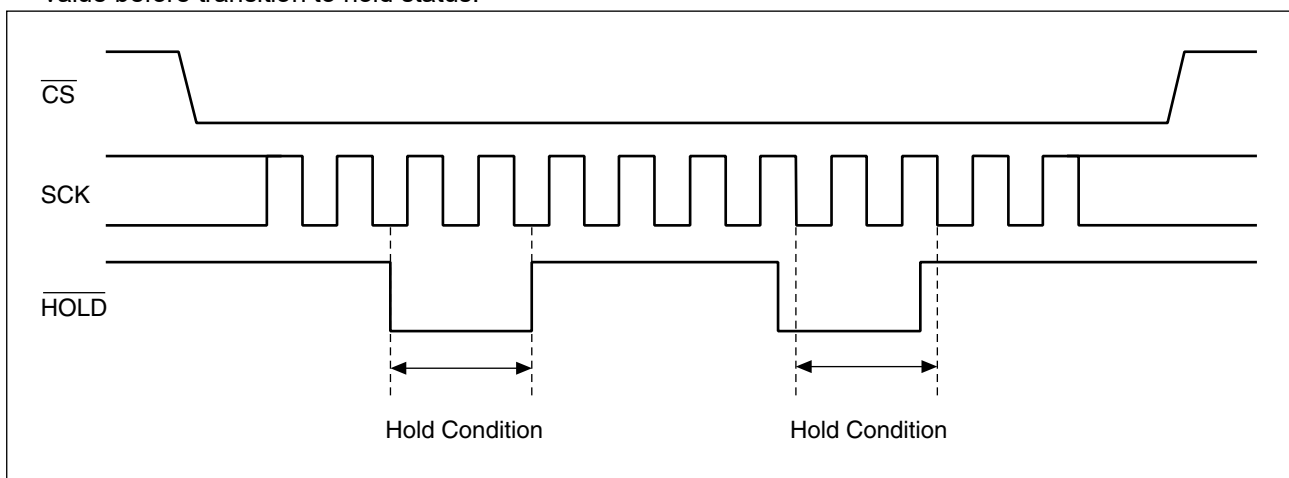

■ ABSOLUTE MAXIMUM RATINGS

Parameter	Symbol	Rating		Unit
		Min	Max	
Power supply voltage*	V_{DD}	- 0.5	+ 4.0	V
Input voltage*	V_{IN}	- 0.5	$V_{DD} + 0.5$	V
Output voltage*	V_{OUT}	- 0.5	$V_{DD} + 0.5$	V
Operation ambient temperature	T_A	- 40	+ 85	°C
Storage temperature	T_{stg}	- 55	+ 125	°C

*:These parameters are based on the condition that V_{SS} is 0 V.

WARNING: Semiconductor devices may be permanently damaged by application of stress (including, without limitation, voltage, current or temperature) in excess of absolute maximum ratings. Do not exceed any of these ratings.

■ RECOMMENDED OPERATING CONDITIONS

Parameter	Symbol	Value			Unit
		Min	Typ	Max	
Power supply voltage ¹	V_{DD}	2.7	3.3	3.6	V
Operation ambient temperature ²	T_A	- 40	—	+ 85	°C

*1: These parameters are based on the condition that V_{SS} is 0 V.

*2: Ambient temperature when only this device is working. Please consider it to be the almost same as the package surface temperature.

WARNING: The recommended operating conditions are required in order to ensure the normal operation of the semiconductor device. All of the device's electrical characteristics are warranted when the device is operated under these conditions.

Any use of semiconductor devices will be under their recommended operating condition. Operation under any conditions other than these conditions may adversely affect reliability of device and could result in device failure.

No warranty is made with respect to any use, operating conditions or combinations not represented on this data sheet. If you are considering application under any conditions other than listed herein, please contact sales representatives beforehand.

■ ELECTRICAL CHARACTERISTICS

1. DC Characteristics

(within recommended operating conditions)

Parameter	Symbol	Condition	Value			Unit
			Min	Typ	Max	
Input leakage current	I _{LI}	$0 \leq \overline{CS} < V_{DD}$	—	—	200	μA
		$\overline{CS} = V_{DD}$	—	—	10	
		$\overline{WP}, \overline{HOLD}, SCK,$ $SI = 0 \text{ V to } V_{DD}$	—	—	10	
Output leakage current	I _{LO}	$SO = 0 \text{ V to } V_{DD}$	—	—	10	μA
Operating power supply current	I _{DD}	SCK = 10 MHz	—	0.75	—	mA
		SCK = 20 MHz	—	1.5	2.4	mA
Standby current	I _{SB}	SCK = SI = $\overline{CS} = V_{DD}$	—	5	15	μA
Input high voltage	V _{IH}	$V_{DD} = 2.7 \text{ V to } 3.6 \text{ V}$	$V_{DD} \times 0.8$	—	$V_{DD} + 0.3$	V
Input low voltage	V _{IL}	$V_{DD} = 2.7 \text{ V to } 3.6 \text{ V}$	-0.5	—	$V_{DD} \times 0.2$	V
Output high voltage	V _{OH}	I _{OH} = -2 mA	$V_{DD} - 0.5$	—	V_{DD}	V
Output low voltage	V _{OL}	I _{OL} = 2 mA	V _{SS}	—	0.4	V
Pull up resistance for \overline{CS}	RP	—	18	33	80	kΩ

2. AC Characteristics

Parameter	Symbol	Value		Unit
		Min	Max	
SCK clock frequency	f_{CK}	0	20	MHz
Clock high time	t_{CH}	25	—	ns
Clock low time	t_{CL}	25	—	ns
Chip select set up time	t_{CSU}	10	—	ns
Chip select hold time	t_{CSH}	10	—	ns
Output disable time	t_{OD}	—	20	ns
Output data valid time	t_{ODV}	—	18	ns
Output hold time	t_{OH}	0	—	ns
Deselect time	t_D	60	—	ns
Data rising time	t_R	—	50	ns
Data falling time	t_F	—	50	ns
Data set up time	t_{SU}	5	—	ns
Data hold time	t_H	5	—	ns
$\overline{\text{HOLD}}$ set up time	t_{HS}	10	—	ns
$\overline{\text{HOLD}}$ hold time	t_{HH}	10	—	ns
$\overline{\text{HOLD}}$ output floating time	t_{HZ}	—	20	ns
$\overline{\text{HOLD}}$ output active time	t_{LZ}	—	20	ns

AC Test Condition

Power supply voltage : 2.7 V to 3.6 V
 Operation ambient temperature : - 40 °C to + 85 °C
 Input voltage magnitude : 0.3 V to 2.7 V
 Input rising time : 5 ns
 Input falling time : 5 ns
 Input judge level : $V_{DD}/2$
 Output judge level : $V_{DD}/2$

AC Load Equivalent Circuit

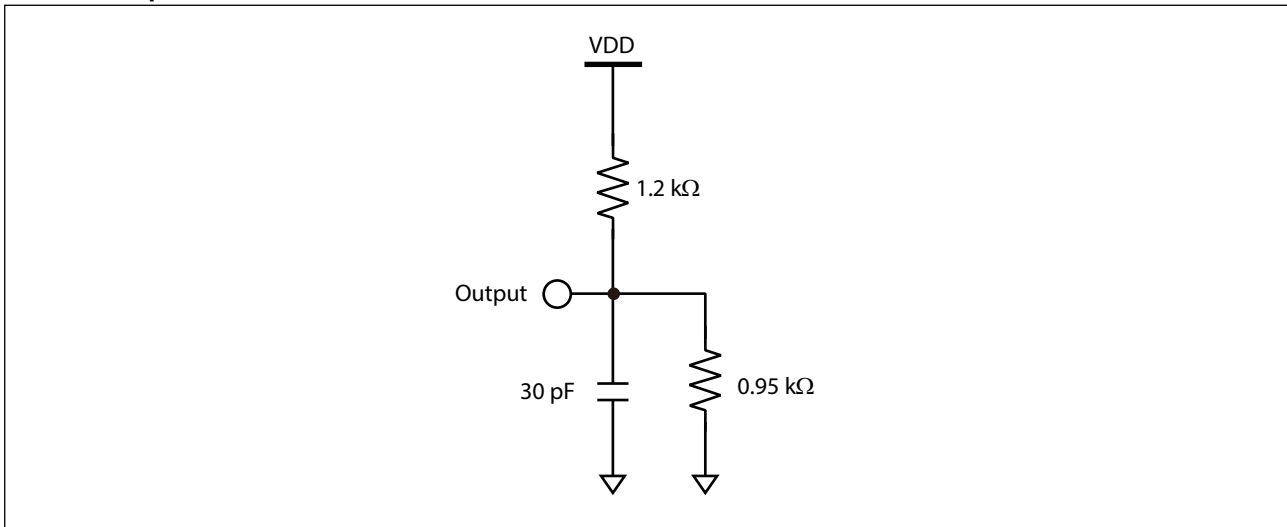

3. Pin Capacitance

Parameter	Symbol	Conditions	Value		Unit
			Min	Max	
Output capacitance	C_o	$V_{DD} = 3.3V,$ $V_{IN} = V_{OUT} = 0 V \sim V_{DD},$ $f = 1 MHz, T_A = + 25 ^\circ C$	—	10	pF
Input capacitance	C_i		—	10	pF

■ TIMING DIAGRAM

• Serial Data Timing

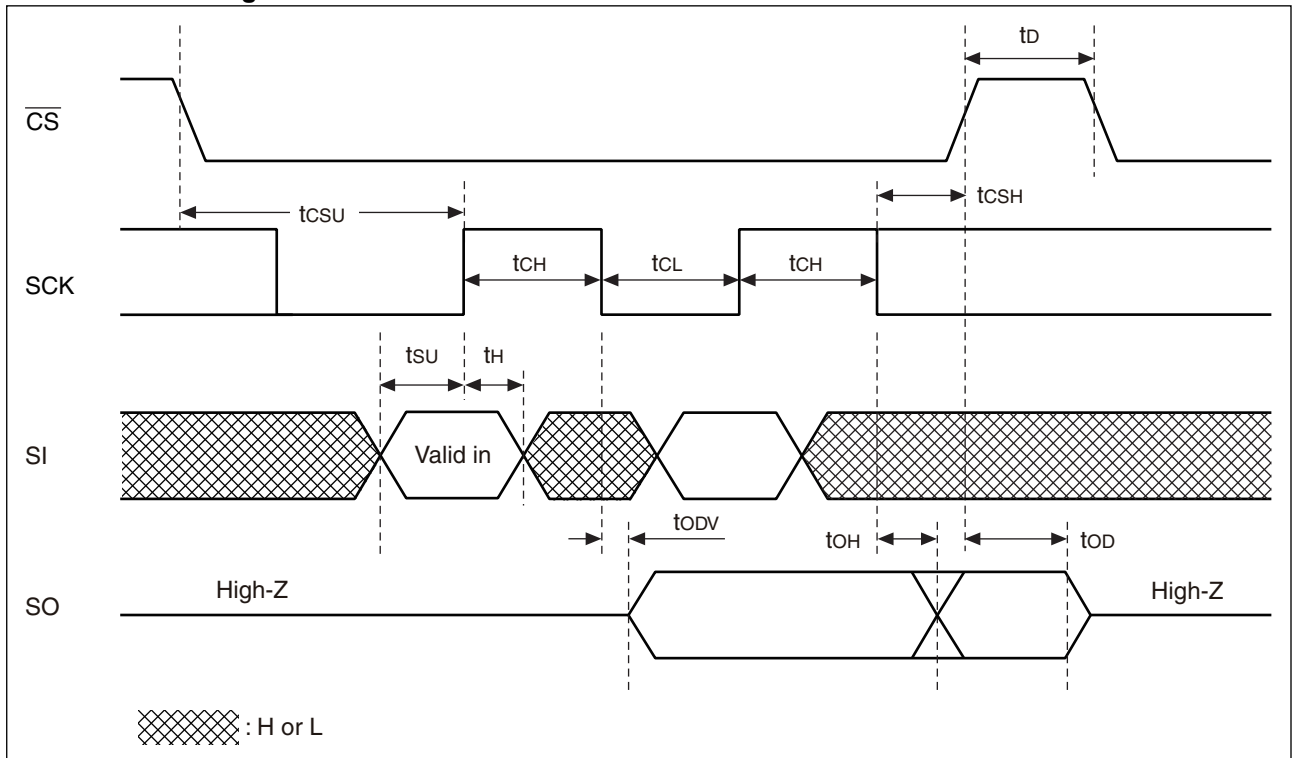

• Hold Timing

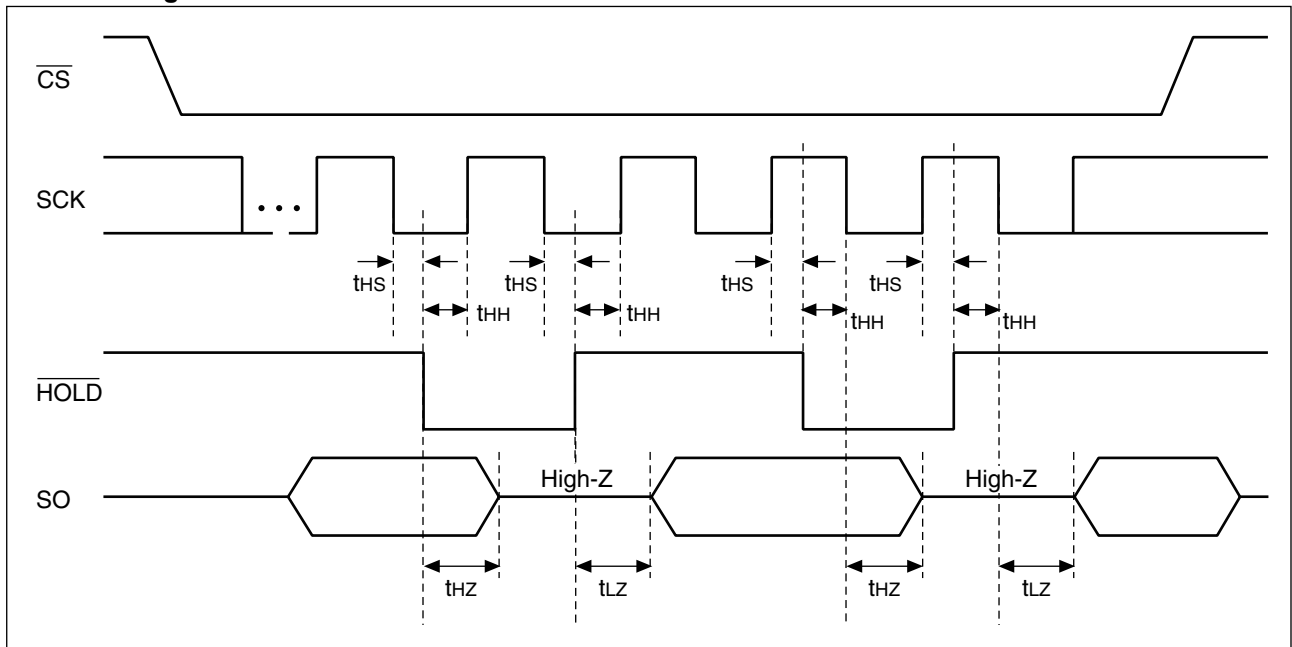

■ POWER ON/OFF SEQUENCE

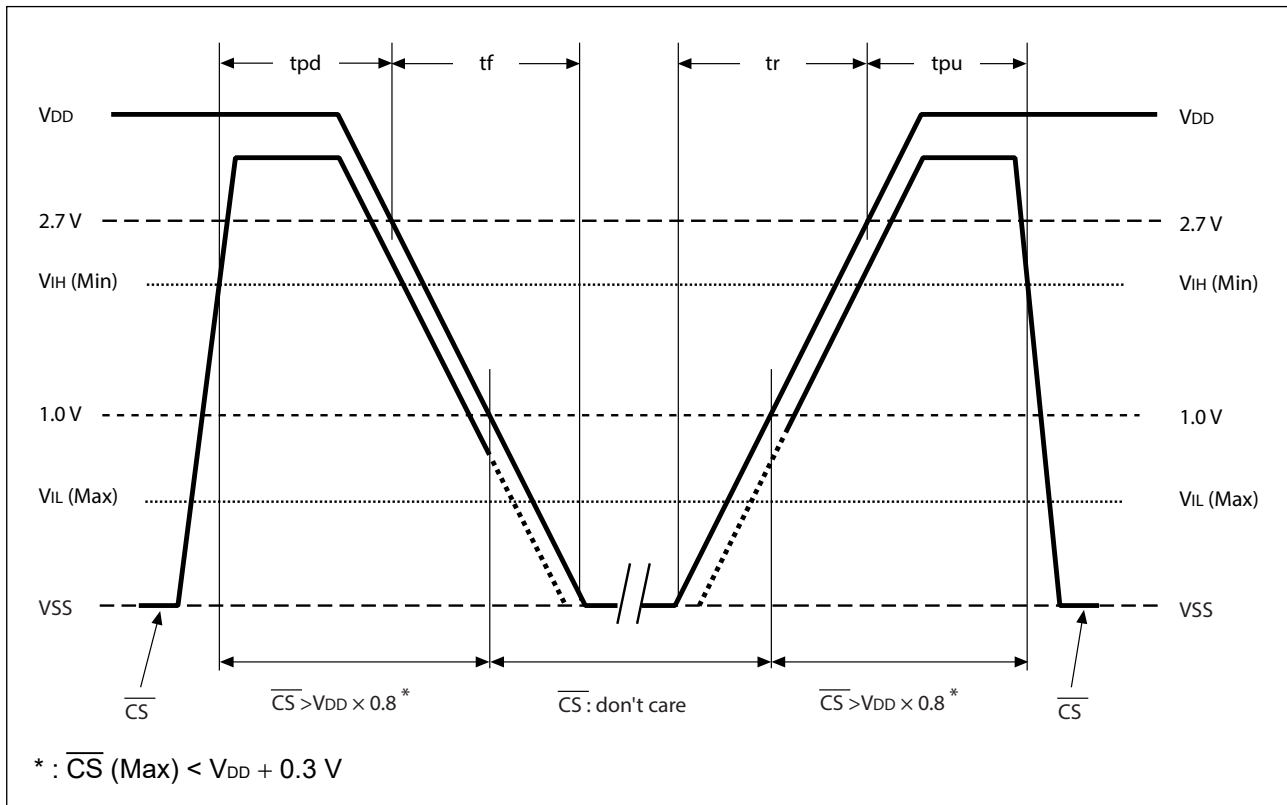

Parameter	Symbol	Value		Unit
		Min	Max	
\overline{CS} level hold time at power OFF	tpd	400	—	ns
\overline{CS} level hold time at power ON	tpu	0.1	—	ms
Power supply falling time	tf	100	—	$\mu\text{s/V}$
Power supply rising time	tr	30	—	$\mu\text{s/V}$

If the device does not operate within the specified conditions of read cycle, write cycle or power on/off sequence, memory data can not be guaranteed.

■ FeRAM CHARACTERISTICS

Item	Min	Max	Unit	Parameter
Read/Write Endurance*1	10^{12}	—	Times/byte	Operation Ambient Temperature $T_A = +85 \text{ }^\circ\text{C}$
Data Retention*2	10	—	Years	Operation Ambient Temperature $T_A = +85 \text{ }^\circ\text{C}$
	95	—		Operation Ambient Temperature $T_A = +55 \text{ }^\circ\text{C}$
	≥ 200	—		Operation Ambient Temperature $T_A = +35 \text{ }^\circ\text{C}$

*1 : Total number of reading and writing defines the minimum value of endurance, as an FeRAM memory operates with destructive readout mechanism.

*2 : Minimum values define retention time of the first reading/writing data right after shipment, and these values are calculated by qualification results.

■ NOTE ON USE

We recommend programming of the device after reflow. Data written before reflow cannot be guaranteed.

■ ESD AND LATCH-UP

Test	DUT	Value
ESD HBM (Human Body Model) JESD22-A114 compliant	MB85RS64PNF-G-JNE1 MB85RS64PNF-G-JNERE1 MB85RS64PNF-G-AME2 MB85RS64PNF-G-AMERE2	$\geq 2000 \text{ V} $
ESD MM (Machine Model) JESD22-A115 compliant		$\geq 200 \text{ V} $
ESD CDM (Charged Device Model) JESD22-C101 compliant		$\geq 1000 \text{ V} $
Latch-Up (C-V Method) Proprietary method		$\geq 200 \text{ V} $

- C-V method of Latch-Up Resistance Test

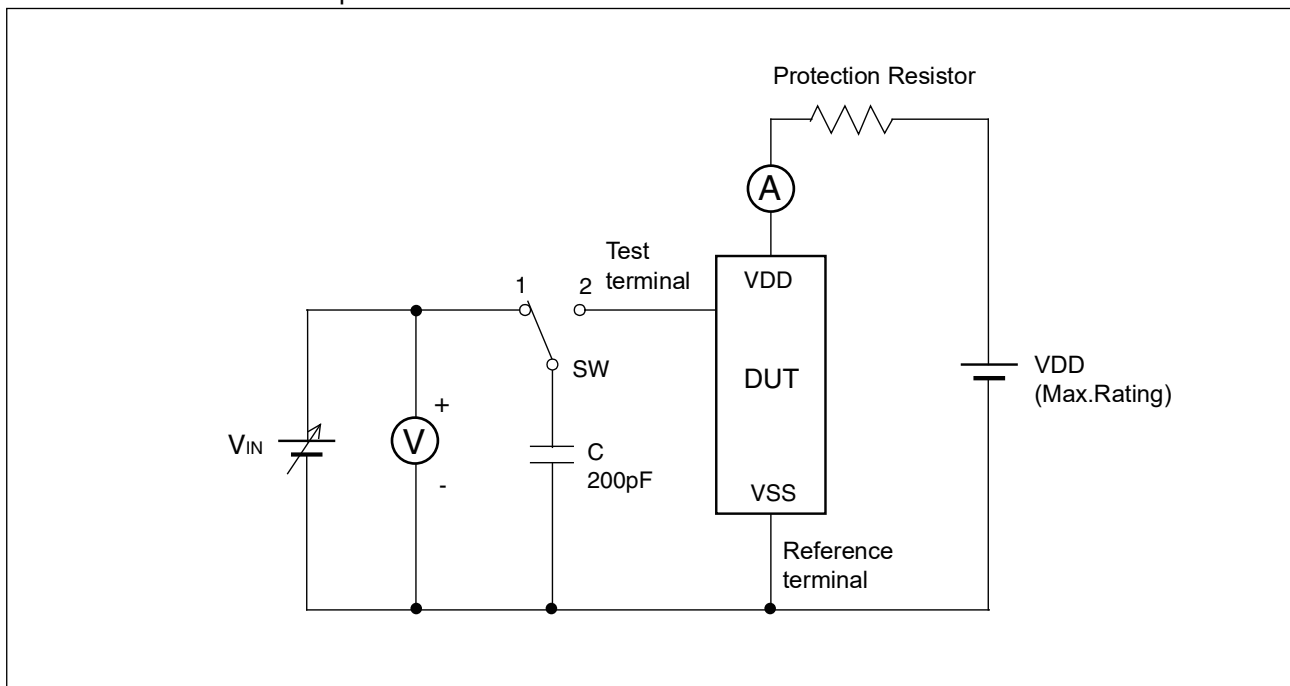

Note : Charge voltage alternately switching 1 and 2 approximately 2 sec interval. This switching process is considered as one cycle.
Repeat this process 5 times. However, if the latch-up condition occurs before completing 5 times, this test must be stopped immediately.

■ REFLOW CONDITIONS AND FLOOR LIFE

[JEDEC MSL] : Moisture Sensitivity Level 1 (IPC/JEDEC J-STD-020E)
MB85RS64PNF-G-AME2 /MB85RS64PNF-G-AMERE2

[JEDEC MSL] : Moisture Sensitivity Level 3 (IPC/JEDEC J-STD-020E)
MB85RS64PNF-G-JNE1 /MB85RS64PNF-G-JNERE1

■ CURRENT STATUS ON CONTAINED RESTRICTED SUBSTANCES

This product complies with the regulations of REACH Regulations, EU RoHS Directive and China RoHS.

■ ORDERING INFORMATION

Part number	Package	Shipping form	Minimum shipping quantity
MB85RS64PNF-G-JNE1	8-pin plastic SOP	Tube	—*
MB85RS64PNF-G-JNERE1	8-pin plastic SOP	Embossed Carrier tape	1500
MB85RS64PNF-G-AME2	8-pin plastic SOP	Tray	—*
MB85RS64PNF-G-AMERE2	8-pin plastic SOP	Embossed Carrier tape	1500

*: Please contact our sales office about minimum shipping quantity.

MB85RS64

■ PACKAGE DIMENSION

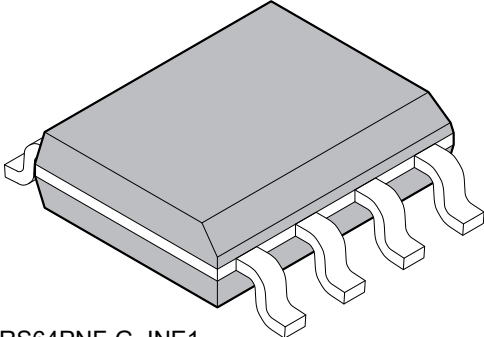
<p>8-pin plastic SOP(150mil)</p>  <p>MB85RS64PNF-G-JNE1 MB85RS64PNF-G-JNERE1 MB85RS64PNF-G-AME2 MB85RS64PNF-G-AMERE2</p>	Lead pitch	1.27mm
	Package width x Package length	3.90mm x 4.90mm
	Lead shape	Gullwing
	Sealing method	Plastic mold
	Mounting height	1.75mm MAX.

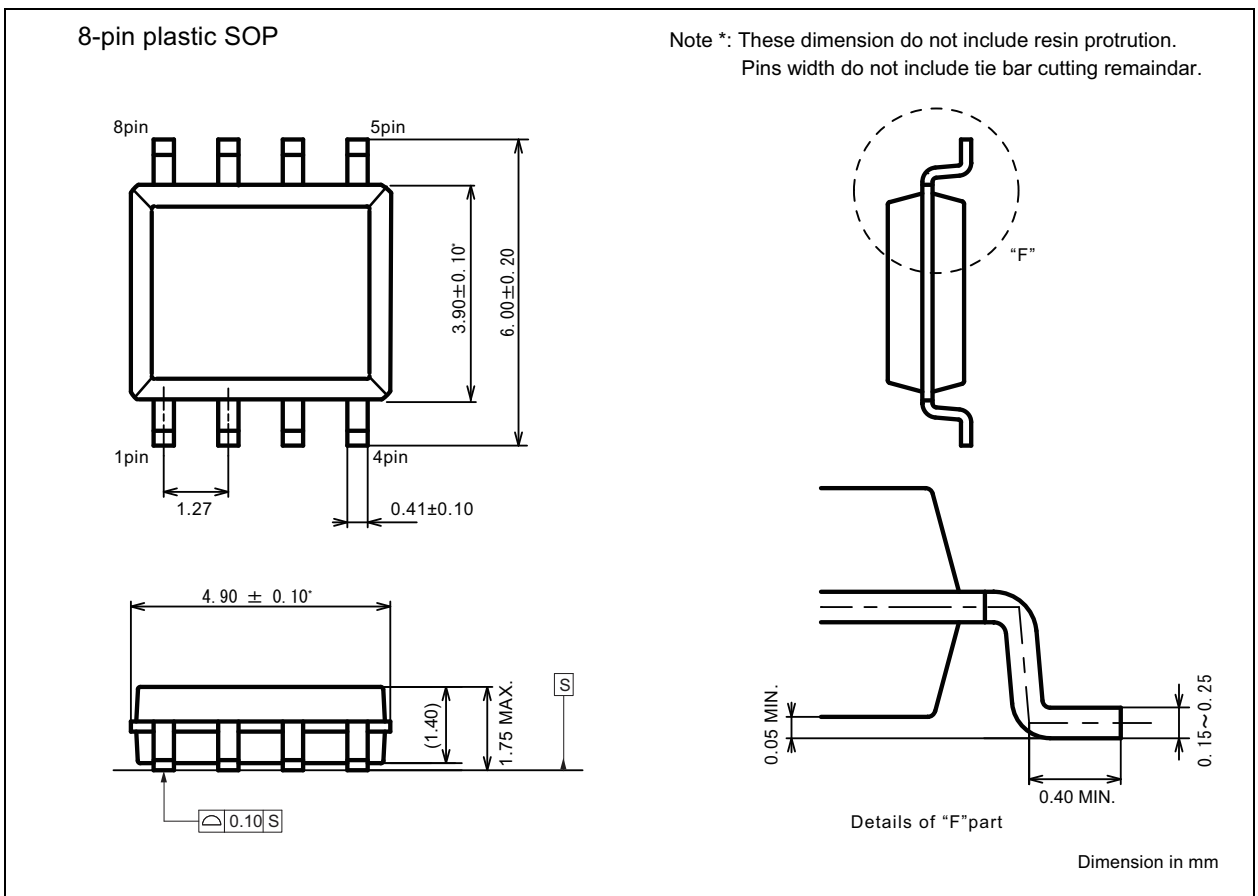

■ MARKING

[MB85RS64PNF-G-JNE1]
[MB85RS64PNF-G-JNERE1]



[8-pin plastic SOP,150mil]

RS64: Product Name
E11150: E1(Lead free code) + 1150(Year and Week code)
300: Trace code

[MB85RS64PNF-G-AME2]
[MB85RS64PNF-G-AMERE2]

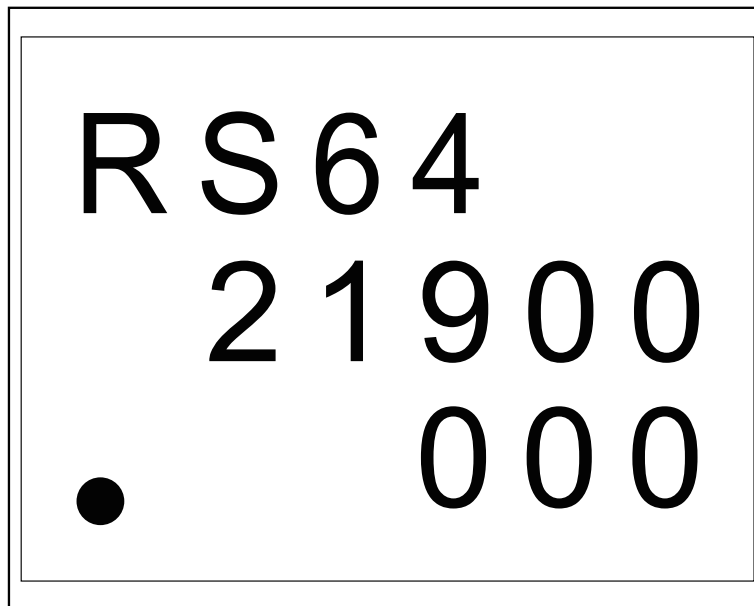

[8-pin plastic SOP,150mil]

RS64: Product Name
21900: 2(Lead free code) + 1900(Year and Week code)
000: Trace code

MB85RS64

■ PACKING INFORMATION

1. Tube(MB85RS64PNF-G-JNE1)

1.1 Tube Dimensions

- Tube/stopper shape

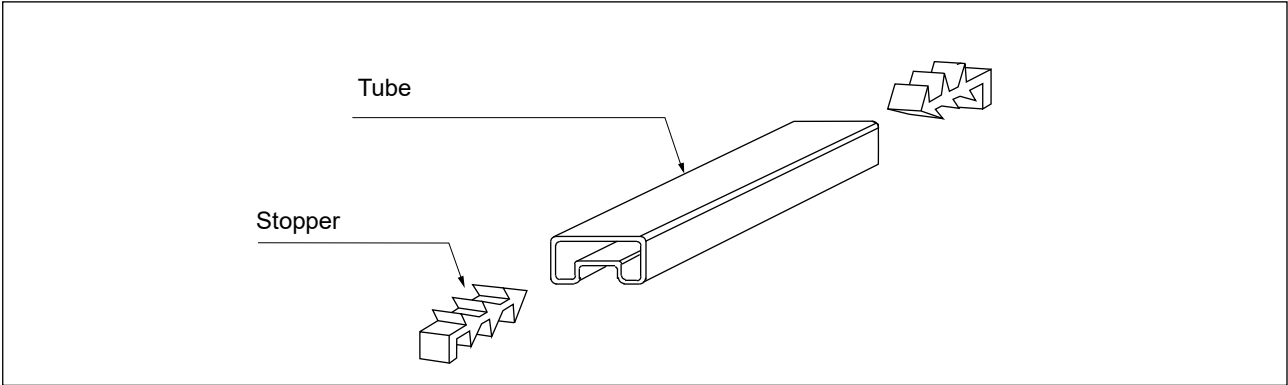

Tube cross-sections and Maximum quantity

MB85RS1MTPNF-G-JNE1	Maximum quantity		
	ICs/tube	ICs/inner box	ICs/outer box
	95	7,600	30,400

7.7
3.8

tube length:521

No heat resistance.
Package should not be baked by using tube.

(Dimensions in mm)

- Tube orientation

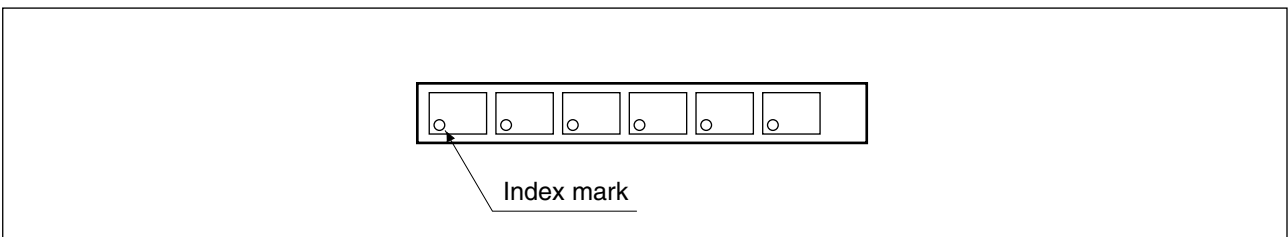

MB85RS64

1.3 Dimensions for Containers

(1) Dimensions for inner box

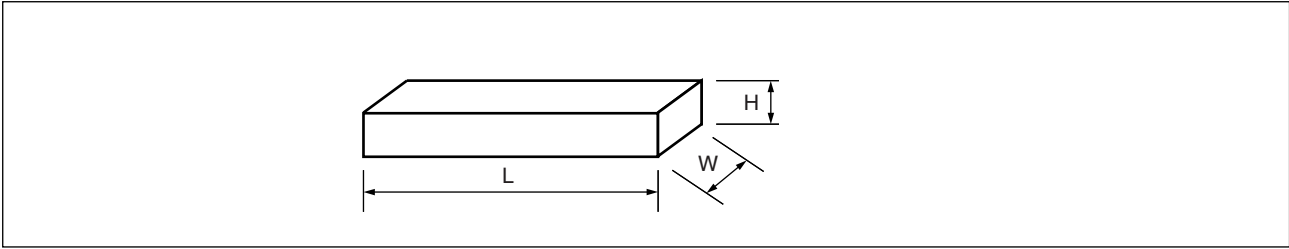

L	W	H
540	125	75

(Dimensions in mm)

(2) Dimensions for outer box

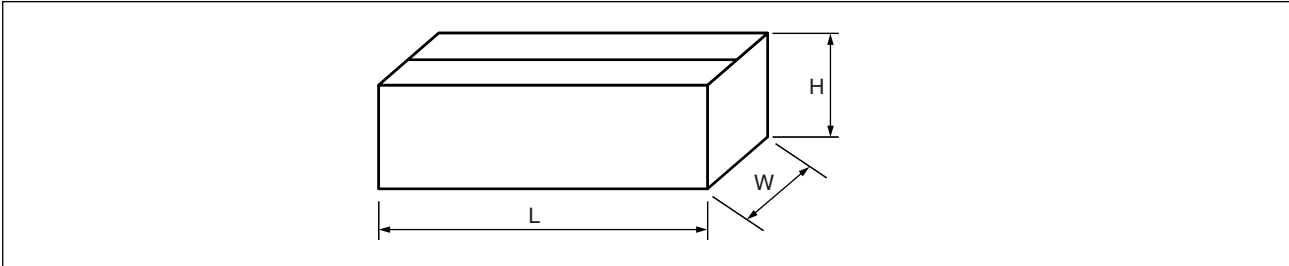

L	W	H
565	270	180

(Dimensions in mm)

2. Emboss Tape(MB85RS64PNF-G-JNERE1/MB85RS64PNF-G-AMERE2)

2.1 Tape Dimensions (not drawn to scale)(8-pin SOP, 150mil)

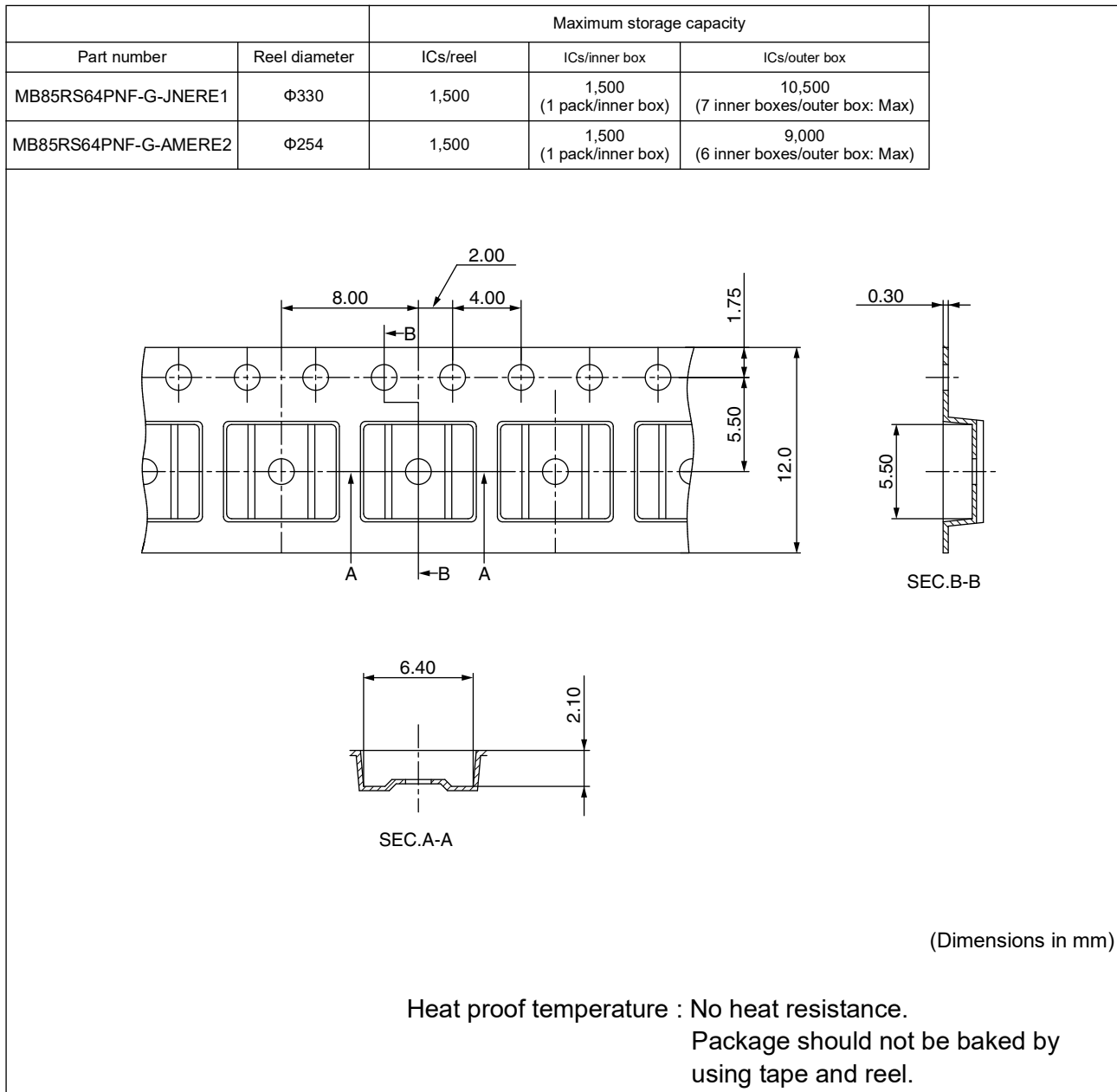

MB85RS64

2.2 IC orientation

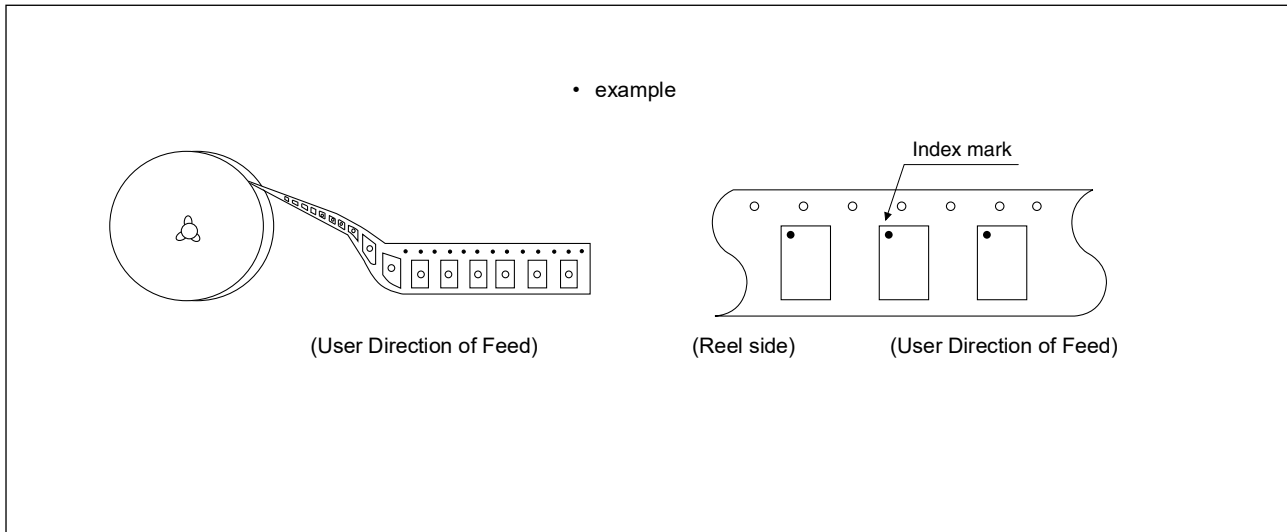

2.3 Reel dimensions

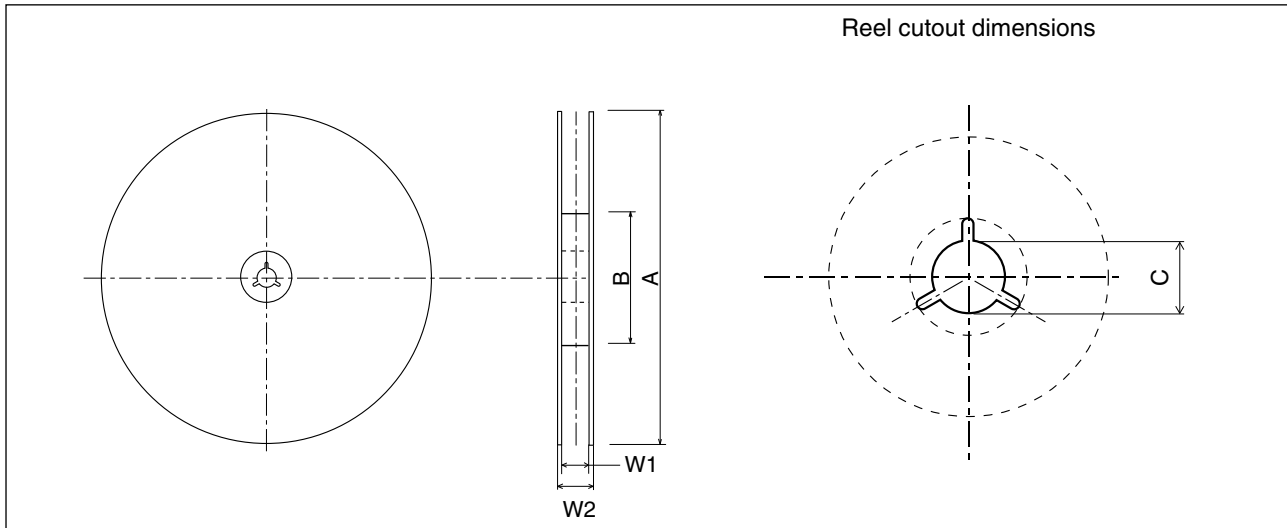

Dimensions in mm

Part number	A	B	C	W1	W2
MB85RS64PNF-G-JNERE1	330	100	13	12.4	17.2
MB85RS64PNF-G-AMERE2	254	100	13	13.5	17.5

2.4 Product label indicators

Label I: Label on Inner box/Moisture Barrier Bag/ (It sticks it on the reel for the emboss taping)
 [C-3 Label (50mm × 100mm) Supplemental Label (20mm × 100mm)]

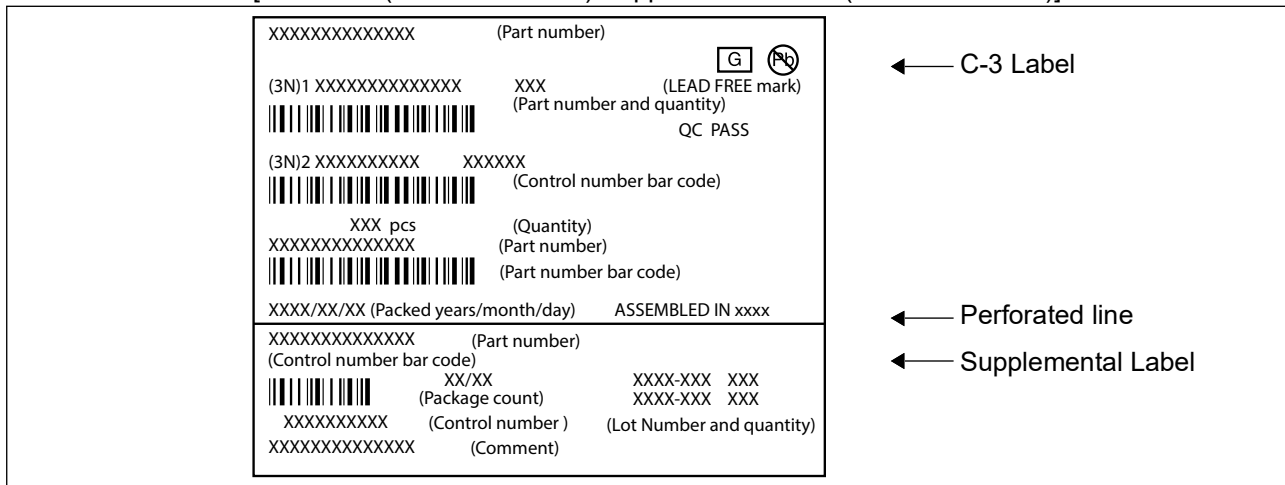

MB85RS64

2.5 Dimensions for Containers

(1) Dimensions for inner box

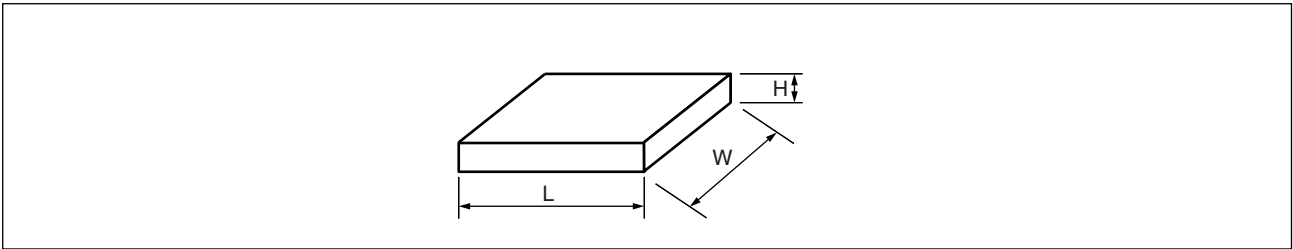

	L	W	H
MB85RS64PNF-G-JNERE1	365	345	40
MB85RS64PNF-G-AMERE2	265	262	51

(Dimensions in mm)

(2) Dimensions for outer box

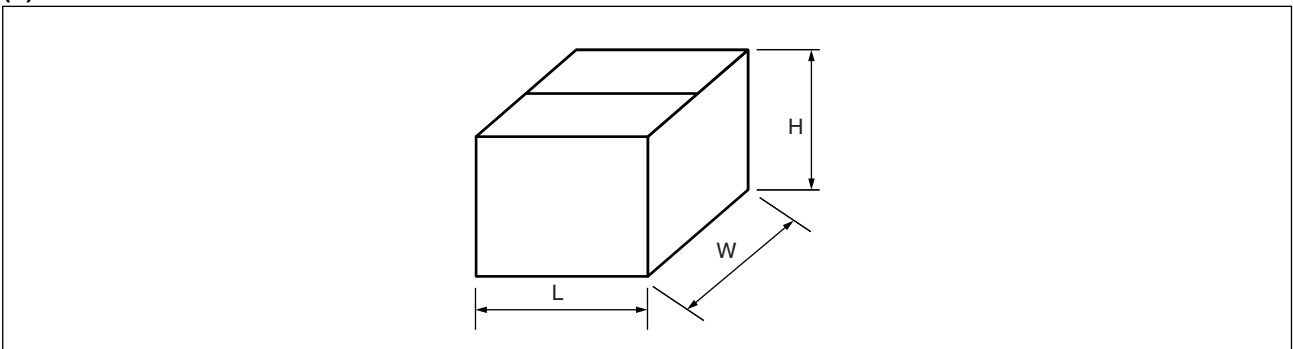

	L	W	H
MB85RS64PNF-G-JNERE1	415	400	315
MB85RS64PNF-G-AMERE2	565	270	180

(Dimensions in mm)

3. Tray(MB85RS64PNF-G-AME2)

3.1 Tray Storage Capacity

Maximum storage capacity		
ICs/tray	ICs/inner box	ICs/outer box
476	4,760 (Max:10 trays/inner box)	19,040 (Max: 4 inner boxes/outer box)

3.2 Tray Dimensions (JEDEC Standard)

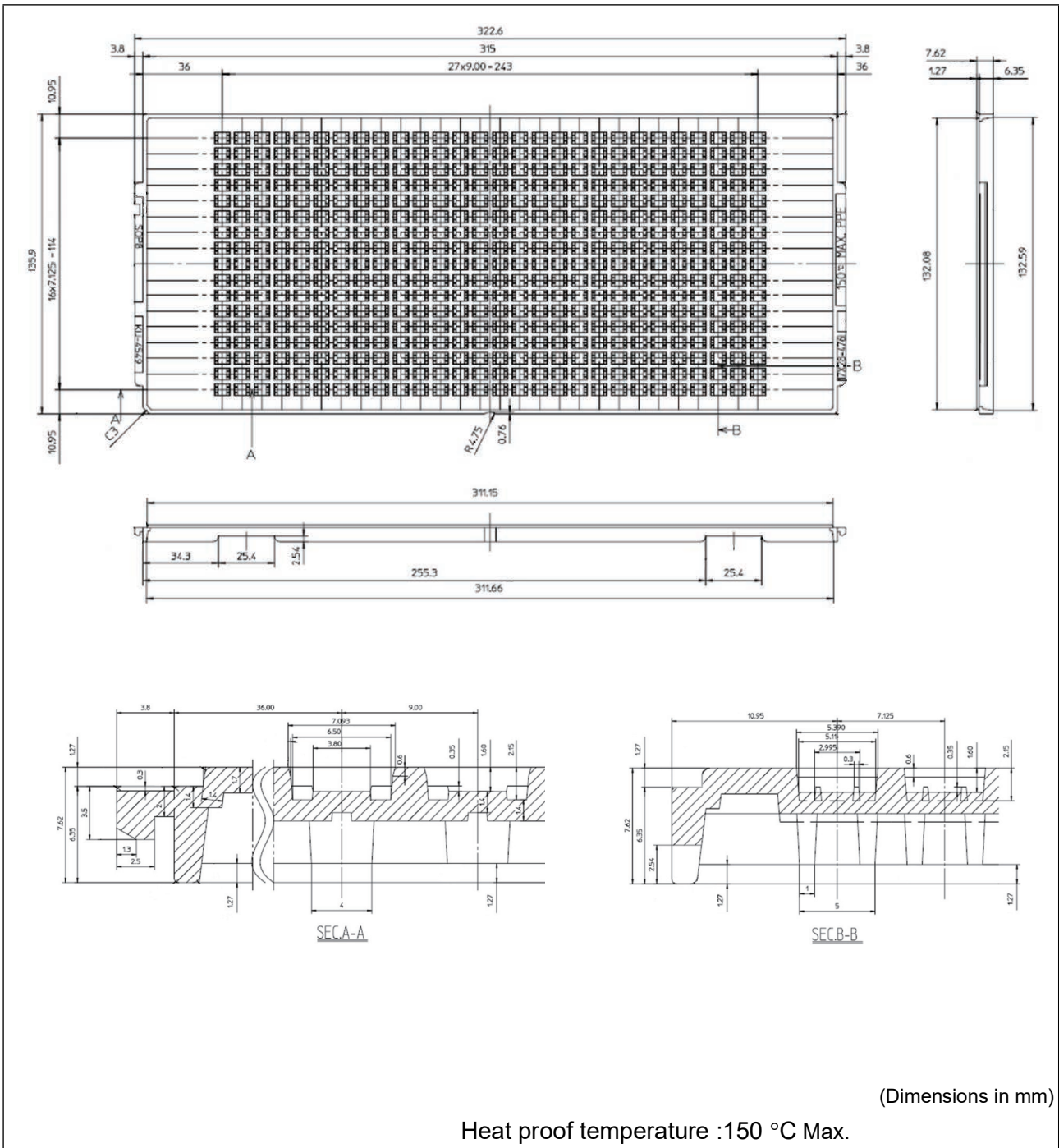

MB85RS64

3.3 IC Orientation

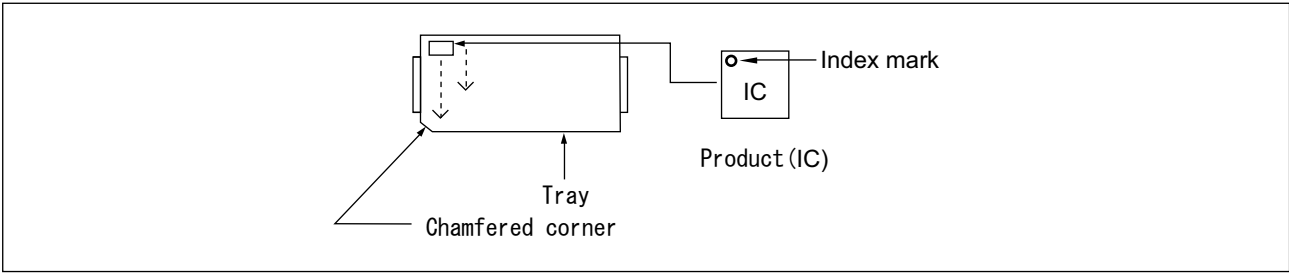

3.4 Product label indicators (an example)

Label on Inner box/Moisture Barrier Bag

[C-3 Label (50mm x 100mm) Supplemental Label (20mm x 100mm)]

<p>XXXXXXXXXXXXX (Part number)</p> <p>(3N)1 XXXXXXXXXXXXXXXX XXX (LEAD FREE mark) (Part number and quantity)</p> <p>XXXXXXXXXXXXX (Control number bar code)</p> <p>XXXXXXXXXXXXX (Quantity)</p> <p>XXXXXXXXXXXXX (Part number)</p> <p>XXXXXXXXXXXXX (Part number bar code)</p> <p>XXXX/XX/XX (Packed years/month/day) ASSEMBLED IN xxxx</p> <hr/> <p>XXXXXXXXXXXXX (Part number)</p> <p>XXXXXXXXXXXXX (Control number bar code)</p> <p>XX/XX (Package count) XXXX-XXX XXX</p> <p>XXXXXXXXXXXXX (Control number) XXXX-XXX XXX</p> <p>XXXXXXXXXXXXX (Lot Number and quantity)</p> <p>XXXXXXXXXXXXX (Comment)</p>	<p>← C-3 Label</p> <p>← Perforated line</p> <p>← Supplemental Label</p>
--	---

3.5 Dimensions for Containers

(1) Dimensions for inner box

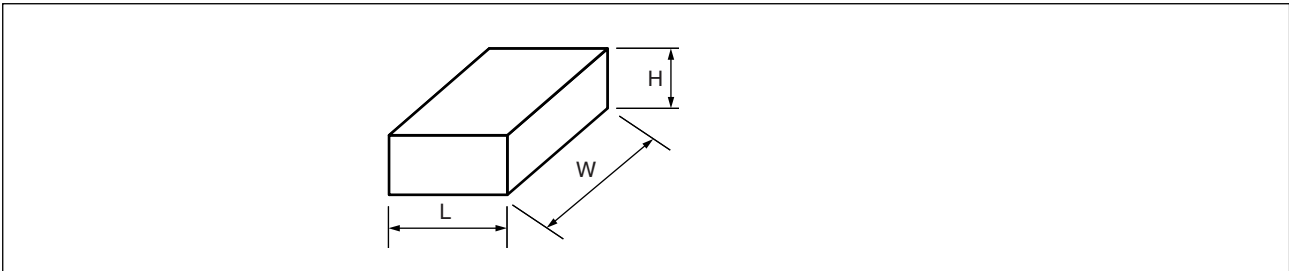

L	W	H
165	360	75

(Dimensions in mm)

(2) Dimensions for outer box

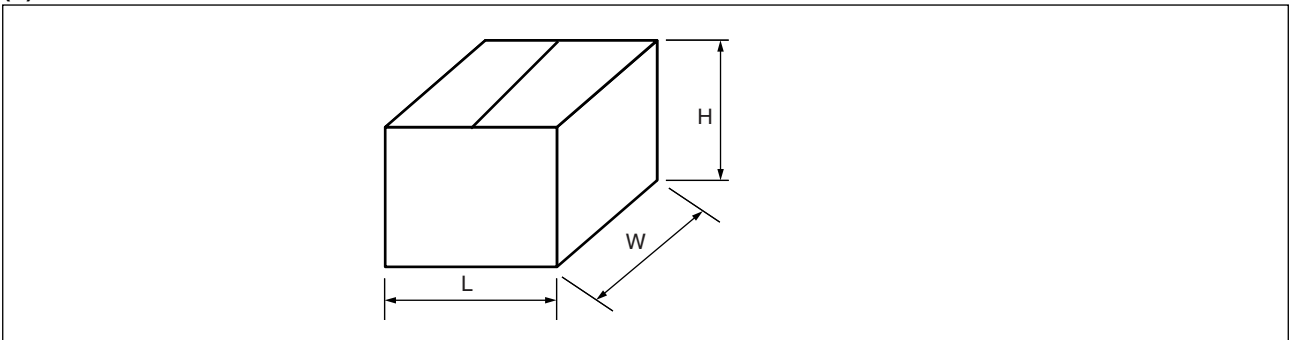

L	W	H
355	385	195

(Dimensions in mm)

■ MAJOR CHANGES IN THIS EDITION

A change on a page is indicated by a vertical line drawn on the left side of that page.

Page	Section	Change Results
14	Pin capacitance	Update about "Conditions".
16	REFLOW CONDITIONS AND FLOOR LIFE	Add Moisture Sensitivity Level 1.

MB85RS64

RAMXEED LIMITED

Shin-Yokohama Chuo Building, 2-100-45 Shin-Yokohama,
Kohoku-ku, Yokohama, Kanagawa 222-0033, Japan
<https://ramxeed.com/>

All Rights Reserved.

RAMXEED LIMITED, its subsidiaries and affiliates (collectively, "RAMXEED ") reserves the right to make changes to the information contained in this document without notice. Please contact your RAMXEED sales representatives before order of RAMXEED device.

Information contained in this document, such as descriptions of function and application circuit examples is presented solely for reference to examples of operations and uses of RAMXEED device. RAMXEED disclaims any and all warranties of any kind, whether express or implied, related to such information, including, without limitation, quality, accuracy, performance, proper operation of the device or non-infringement. If you develop equipment or product incorporating the RAMXEED device based on such information, you must assume any responsibility or liability arising out of or in connection with such information or any use thereof. RAMXEED assumes no responsibility or liability for any damages whatsoever arising out of or in connection with such information or any use thereof.

Nothing contained in this document shall be construed as granting or conferring any right under any patents, copyrights, or any other intellectual property rights of RAMXEED or any third party by license or otherwise, express or implied. RAMXEED assumes no responsibility or liability for any infringement of any intellectual property rights or other rights of third parties resulting from or in connection with the information contained herein or use thereof.

The products described in this document are designed, developed and manufactured as contemplated for general use including without limitation, ordinary industrial use, general office use, personal use, and household use, but are not designed, developed and manufactured as contemplated (1) for use accompanying fatal risks or dangers that, unless extremely high levels of safety is secured, could lead directly to death, personal injury, severe physical damage or other loss (including, without limitation, use in nuclear facility, aircraft flight control system, air traffic control system, mass transport control system, medical life support system and military application), or (2) for use requiring extremely high level of reliability (including, without limitation, submersible repeater and artificial satellite). RAMXEED shall not be liable for you and/or any third party for any claims or damages arising out of or in connection with above-mentioned uses of the products.

Any semiconductor devices fail or malfunction with some probability. You are responsible for providing adequate designs and safeguards against injury, damage or loss from such failures or malfunctions, by incorporating safety design measures into your facility, equipments and products such as redundancy, fire protection, and prevention of overcurrent levels and other abnormal operating conditions.

The products and technical information described in this document are subject to the Foreign Exchange and Foreign Trade Control Law of Japan, and may be subject to export or import laws or regulations in U.S. or other countries. You are responsible for ensuring compliance with such laws and regulations relating to export or re-export of the products and technical information described herein.

All company names, brand names and trademarks herein are property of their respective owners.